

# FM25040

## 4Kb FRAM<sup>®</sup> Serial Memory



### Features

#### 4K bit Ferroelectric Nonvolatile RAM

- Organized as 512 x 8 bits
- High endurance 10 Billion (10<sup>10</sup>) read/writes
- 10 year data retention at 55° C
- No write delay
- Advanced high-reliability ferroelectric process

#### Fast Serial Peripheral Interface - SPI

- Up to 2.1 MHz maximum bus frequency
- Direct hardware replacement for EEPROM
- Supports SPI Mode 0 (CPOL=0, CPHA=0)

#### Sophisticated Write Protection Scheme

- Hardware protection
- Software protection

#### Low Power Consumption

- 10 µA standby current

#### Industry Standard Configuration

- Industrial temperature -40° C to +85° C
- 8-pin SOP or DIP

### Description

The FM25040 is a 4-kilobit nonvolatile memory employing an advanced ferroelectric process. A ferroelectric random access memory or FRAM is nonvolatile but operates in other respects as a RAM. It provides reliable data retention for 10 years while eliminating the complexities, overhead, and system level reliability problems caused by EEPROM and other nonvolatile memories.

Unlike serial EEPROMs, the FM25040 performs write operations at bus speed. No write delays are incurred. Data is written to the memory array mere hundreds of nanoseconds after it has been successfully transferred to the device. The next bus cycle may commence immediately. In addition the product offers substantial write endurance compared with other nonvolatile memories. The FM25040 is capable of supporting up to 1E10 read/write cycles -- far more than most systems will require from a serial memory.

These capabilities make the FM25040 ideal for nonvolatile memory applications requiring frequent or rapid writes. Examples range from data collection, where the number of write cycles may be critical, to demanding industrial controls where the long write time of EEPROM can cause data loss.

The FM25040 provides substantial benefits to users of serial EEPROM, in a hardware drop-in replacement. The FM25040 uses the high-speed SPI bus which enhances the high-speed write capability of FRAM technology. It is guaranteed over an industrial temperature range of -40°C to +85°C.

### Pin Configuration

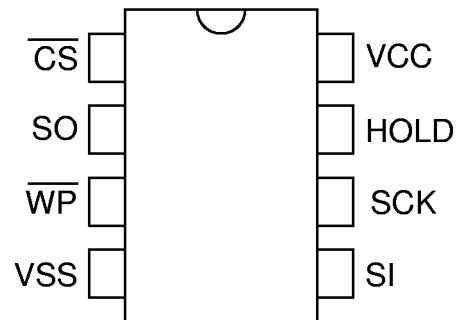

Pin Names	Function
/CS	Chip Select
SO	Serial Data Output
/WP	Write Protect
VSS	Ground
SI	Serial Data Input
SCK	Serial Clock
/HOLD	Hold
VCC	Supply Voltage 5V

### Ordering Information

FM25040-P	8-pin plastic DIP
FM25040-S	8-pin SOP

Figure 1. Block Diagram

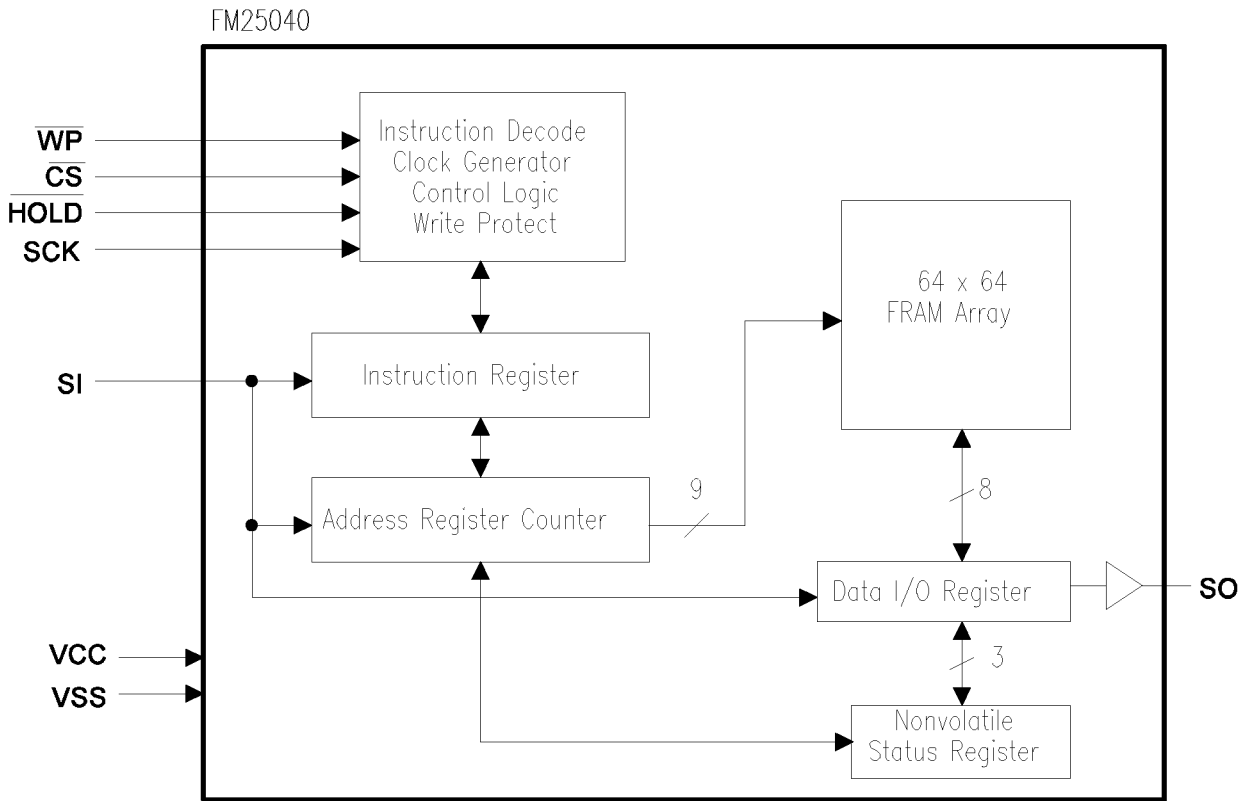

## Pin Description

Pin Name	Pin Number	I/O	Pin Description
/CS	1	I	Chip Select. Activates the device. When high, all outputs are tri-state and the device ignores other inputs. The part remains in a low power standby mode. When low, the part recognizes activity on the SCK signal. A falling edge on /CS must occur prior to every op-code.
SO	2	O	Serial Output. SO is the data output pin. It is driven actively during a read and remains tri-state at all other times including when /HOLD is low. Data transitions are driven on the falling edge of the serial clock. * SO can be connected to SI for a single pin data interface since the part communicates in half-duplex fashion.
/WP	3	I	Write Protect. This pin prevents all write operations. If low, the part is completely write protected. If high, write access is determined by the other write protection features. A complete explanation of write protection is provided below. *Note that the function of /WP is different from the FM25160 where it protects the status register only.
VSS	4	I	Ground
SI	5	I	Serial Input. All data is input to the device on this pin. The pin is sampled on the rising edge of SCK and is ignored at other times. It should always be driven to a valid logic level to meet ICC specifications. * SI may be connected to SO for a single pin data interface.
SCK	6	I	Serial Clock. All I/O activity is synchronized to the serial clock. Inputs are latched on the rising edge and outputs occur on the falling edge. The part is static so the clock frequency may be any value between 0 and 2.1 MHz and may be interrupted at any time.
/HOLD	7	I	Hold. The /HOLD signal is used when the host CPU must interrupt a memory operation for another task. Taking the /HOLD signal to a low state pauses the current operation. The part ignores any transition on SCK or /CS. All transitions on /HOLD must occur while SCK is low.
VCC	8	I	Supply Voltage. 5V

## Overview

The FM25040 is a serial FRAM memory. The memory array is logically organized as 512 x 8 and is accessed using an industry standard Serial Peripheral Interface or SPI bus. Functional operation of the FRAM is similar to serial EEPROMs. The major difference between the FM25040 and a serial EEPROM with the same pin-out relates to its superior write performance.

## Memory Architecture

When accessing the FM25040, the user addresses 512 locations each with 8 data bits. These data bits are shifted serially. The addresses are accessed using the SPI protocol, which includes a chip select (to permit multiple devices on the bus), an op-code including the upper address bit, and a word address. The word address consists of the lower 8-address bits. The complete address of 9-bits specifies each byte address uniquely.

Most functions of the FM25040 are either controlled by the SPI interface or are handled automatically by on-board circuitry. The access time for memory

operation essentially is zero, beyond the time needed for the serial protocol. That is, the memory is read or written at the speed of the SPI bus. Unlike an EEPROM, it is not necessary to poll the device for a ready condition since writes occur at bus speed. That is, by the time a new bus transaction can be shifted into the part, a write operation will be complete. This is explained in more detail in the interface section below.

Users expect several obvious system benefits from the FM25040 due to its fast write cycle and high endurance as compared with EEPROM. However there are less obvious benefits as well. For example in a high noise environment, the fast-write operation is less susceptible to corruption than an EEPROM since it is completed quickly. By contrast an EEPROM requiring milliseconds to write is vulnerable to noise during much of the cycle.

Note that the FM25040 contains no power management circuits other than a simple internal power-on reset. It is the user's responsibility to ensure that VCC is within data sheet tolerances to prevent incorrect operation.

### Serial Peripheral Interface – SPI Bus

The FM25040 employs a Serial Peripheral Interface (SPI) bus. This high-speed serial bus provides high performance serial communication with a host microcontroller. Many common microcontrollers have hardware SPI ports allowing a direct interface. It is quite simple to emulate the SPI interface using ordinary port pins for microcontrollers that do not. Note that the FM25040 operates in SPI Mode 0 only.

The SPI interface uses a total of four pins; clock, data-in, data-out, and chip select. It is possible to connect the two data lines together. Figure 2 illustrates a typical system configuration using the FM25040 with a microcontroller that offers an SPI port. Figure 3 shows a similar configuration for a microcontroller that has no hardware support for the SPI bus.

### Protocol Overview

The SPI interface is a synchronous serial interface using clock and data lines. It is intended to support multiple devices on the bus. Each device is activated using a chip select. Once chip select is activated by the bus master, the FM25040 will begin monitoring the clock and data lines. The relationship between the falling edge of /CS, the clock and data is dictated by the SPI mode. There are four such modes however the FM25040 supports only mode 0. This mode dictates that the SCK signal must be low when /CS is activated.

The SPI protocol is controlled by op-codes. These op-codes specify the commands to the part. After /CS is activated, the first byte transferred from the bus master is the op-code. Following the op-code, any addresses and data are then transferred. Certain op-codes are commands with no subsequent data transfer. The /CS must go inactive after an operation is complete and before a new op-code can be issued.

Figure 2. System Configuration with SPI port

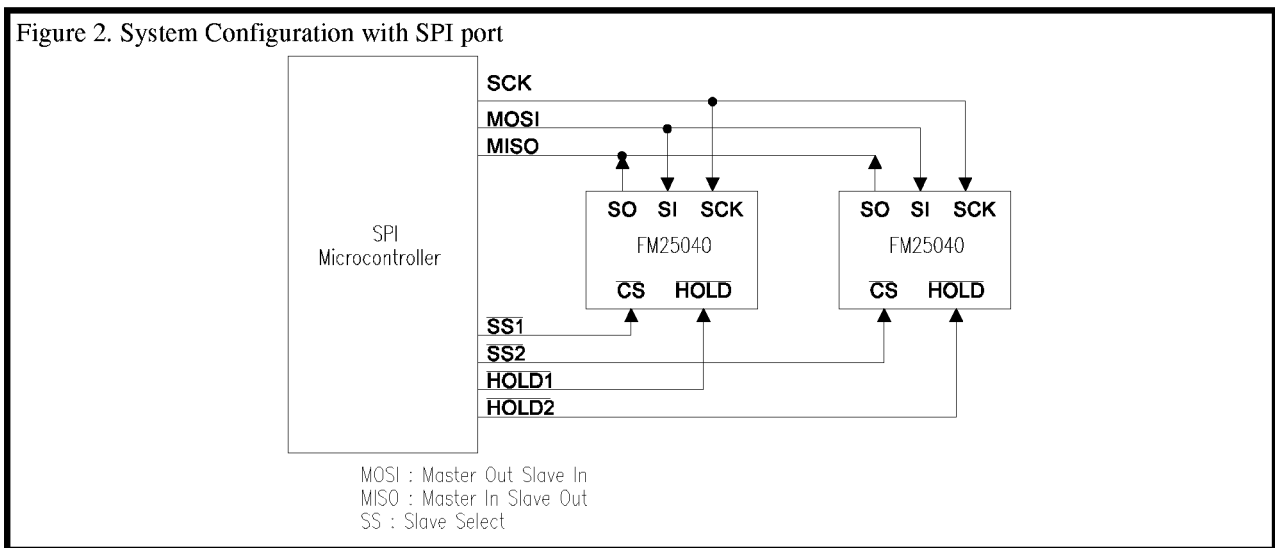
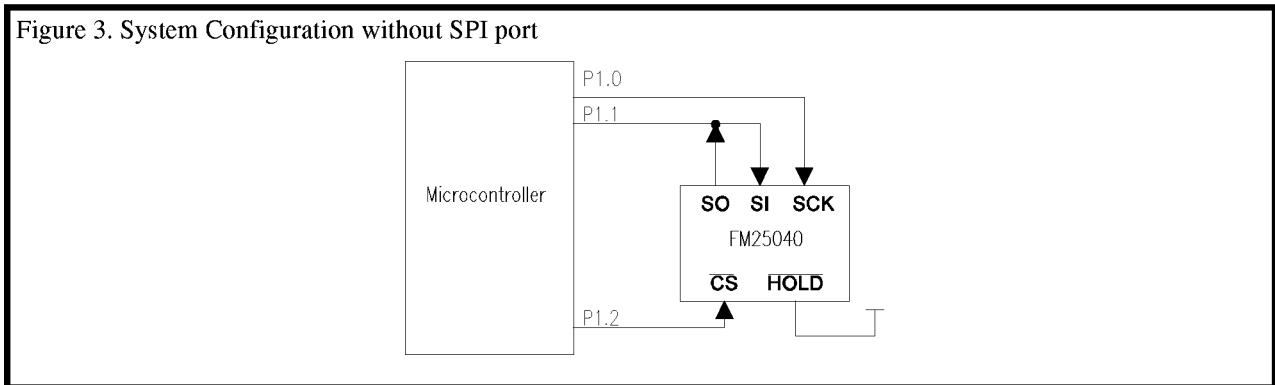

Figure 3. System Configuration without SPI port



Data Transfer

All data transfers to and from the FM25040 occur in 8-bit groups. They are synchronized to the clock signal (SCK) and occur most significant bit (MSB) first. Serial inputs are clocked in on the rising edge of SCK. Outputs are driven on the falling edge of SCK.

Command Structure

There are six commands called op-codes that can be issued by the bus master to the FM25040. They are listed in the table below. These op-codes control the functions performed by the memory. They can be divided into three categories. First, are commands that have no subsequent operands. They perform a single function such as to enable a write operation. Second are commands followed by one byte, either in or out. They operate on the status register Last are commands for memory transactions followed by address and one or more bytes of data.

Table 1. Op-code Commands

Name	Description	Op-code value
WREN	Set Write Enable Latch	00000110
WRDI	Write Disable	00000100
RDSR	Read Status Register	00000101
WRSR	Write Status Register	00000001
READ	Read Memory Data	0000A011
WRITE	Write Memory Data	0000A010

WREN - Set Write Enable Latch

The FM25040 will power up with writes disabled. The WREN command must be issued prior to any write operation. Sending the WREN op-code will allow the user to issue subsequent op-codes for write operations. These include writing the status register and writing the memory.

Sending the WREN op-code causes the internal Write Enable Latch to be set. A flag bit in the status register, called WEL, indicates the state of the latch. WEL=1 indicates that writes are permitted. Attempting to write the WEL bit in the status register has no affect. Completing any write operation (rising edge of /CS) will automatically clear the Write Enable Latch and prevent further writes without another WREN command. Figure 4 below illustrates the WREN command bus configuration.

WRDI - Write Disable

The WRDI command disables all write activity by clearing the Write Enable Latch. The user can verify that writes are disabled by reading the WEL bit in the status register and verifying that WEL=0. Figure 5 below illustrates the WRDI command bus configuration.

Figure 4. WREN Bus Configuration

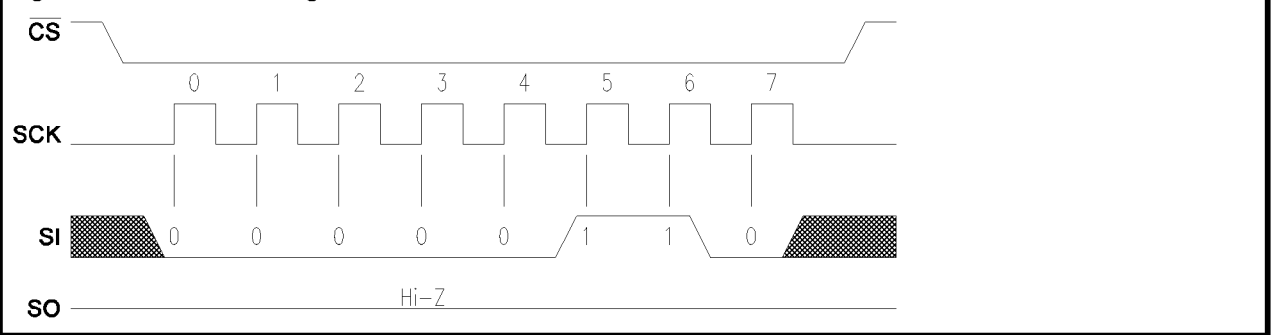
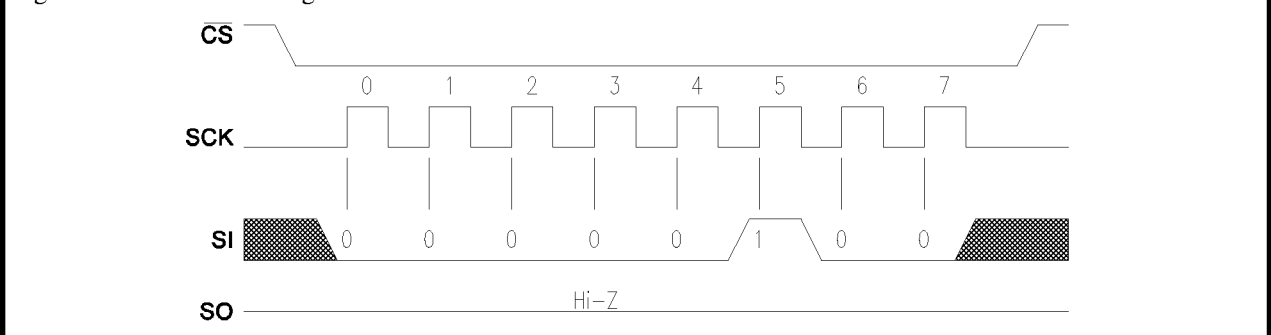

Figure 5. WRDI Bus Configuration



**RDSR - Read Status Register**

The RDSR command allows the bus master to verify the contents of the Status register. Reading Status provides information about the current state of the write protection features. Following the RDSR op-code, the FM25040 will return one byte with the contents of the Status register. The Status register is described in detail in a later section.

**WRSR – Write Status Register**

The WRSR command allows the user to select certain write protection features by writing a byte to the Status register. Prior to issuing a WRSR command, the /WP pin must be high or inactive. Note that on the FM25040 /WP prevents writing to the Status register and the memory array. Also prior to sending the WRSR command, the user must send a WREN command to enable writes. Note that executing a WRSR command is a write operation and therefore clears the Write Enable Latch. The bus configuration of RDSR and WRSR are shown below.

Figure 6. RDSR Bus Configuration

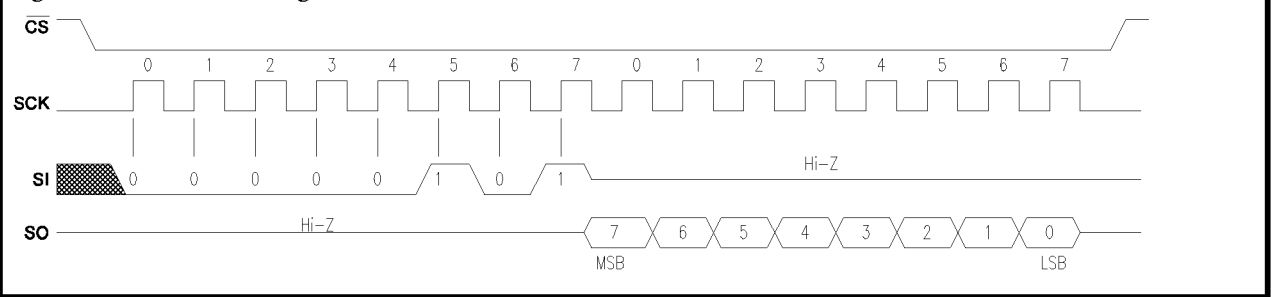
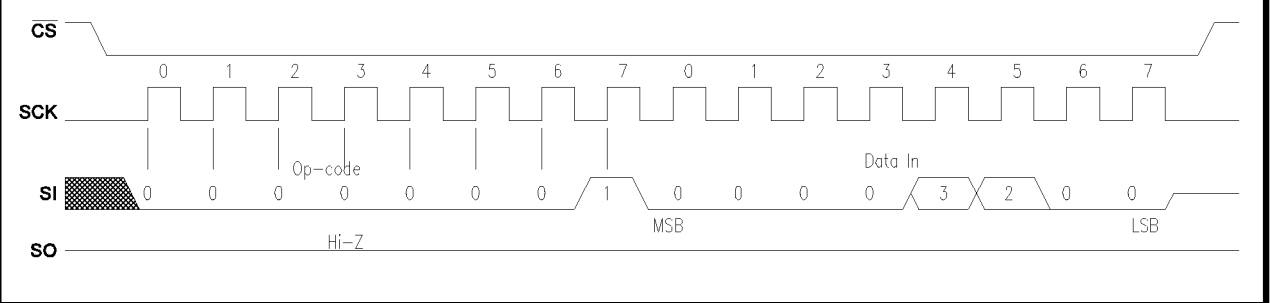

Figure 7. WRSR Bus Configuration



**Status Register & Write Protection**

The write protection features of the FM25040 are relatively simple to use. First, a WREN op-code must be issued prior to any write operation. Assuming that writes are enabled using WREN, writes to memory are controlled by the /WP pin and the Status register. When /WP is low, the entire part is write protected. When /WP is high, the memory protection is subject to the Status register. As described above, writes to the status register are performed using the WRSR command and are subject to the /WP pin. The Status register is organized as follows.

Table 2. Status Register

Bit	7	6	5	4	3	2	1	0
Name	0	0	0	0	BP1	BP0	WEL	0

Bits 0 and 4-7 are fixed at 0 and can not be modified. Note that the Ready bit in many EEPROMs is unnecessary as the FRAM writes in real-time and is never busy. The BP1 and BP0 control write protection features. They are nonvolatile! The WEL flag indicates the state of the Write Enable Latch. Writing the WEL bit in the status register has no affect. BP1 and BP0 are memory block write protection bits. They specify portions of memory that are write protected as shown in the following table.

Table 3. Block Memory Write Protection

BP1	BP0	Protected Address Range
0	0	None
0	1	180h to 1FFh (upper ¼)
1	0	100h to 1FFh (upper ½)
1	1	000h to 1FFh (all)

The BP1 and BP0 bits protect selected portions of the memory array from writes. The /WP pin and Write Enable Latch protect the entire part including the BP bits. The following table summarizes the write protection conditions.

Table 4. Write Protection

WEL	/WP	Protected Blocks	Unprotected Blocks	Status Register
0	X	Protected	Protected	Protected
1	0	Protected	Protected	Protected
1	1	Protected	Unprotected	Unprotected

## Memory Operation

The SPI interface, with its relatively high maximum clock frequency, highlights the fast write capability of the FRAM technology. Unlike SPI bus EEPROMs the FM25040 can perform sequential writes at bus speed. No page register is needed and any number of sequential writes may be performed.

### Write Operation

All writes to the memory array begin with a WREN op-code. The bus master then issues a WRITE op-code. Part of this op-code includes the upper bit of the memory address. Bit 3 in the op-code corresponds to A8. The next byte is the lower 8-bits of the address A7-A0. In total, the 9-bits specify the address of the first byte of the write operation. Subsequent bytes are data and they are written sequentially. Addresses are incremented internally as long as the bus master continues to issue clocks. If the last address of 1FFh is reached, the counter will roll over to 000h. Data is written MSB first.

Unlike EEPROMs, any number of bytes can be written sequentially and each byte is written to memory immediately after it is clocked in (after the 8<sup>th</sup> clock) . The rising edge of /CS terminates a WRITE op-code operation.

### Read Operation

After the falling edge of /CS, the bus master can issue a READ op-code. Part of this op-code includes the upper bit of the memory address. The next byte is the lower 8-bits of the address. In total, the 9-bits specify the address of the first byte of the read operation. After the op-code is complete, the SI line is ignored. The bus master then issues 8 clocks, with one bit read out for each. Addresses are incremented internally as long as the bus master continues to issue clocks. If the last address of 1FFh is reached, the counter will roll over to 000h. Data is read MSB first. The rising edge of /CS terminates a READ op-code operation.. The bus configuration for read and write operations is shown below.

### Hold

The /HOLD pin can be used to interrupt a serial operation without aborting it. If the bus master takes the /HOLD pin low while SCK is low, the current operation will pause. Taking the /HOLD pin high while SCK is low will resume an operation. The transitions of /HOLD must occur while SCK is low, but the SCK and I/O pins can toggle during a hold state. However, before removing the HOLD condition, all pins should return to their state prior to the HOLD. A diagram illustrating the HOLD timing is provided in the electrical specifications.

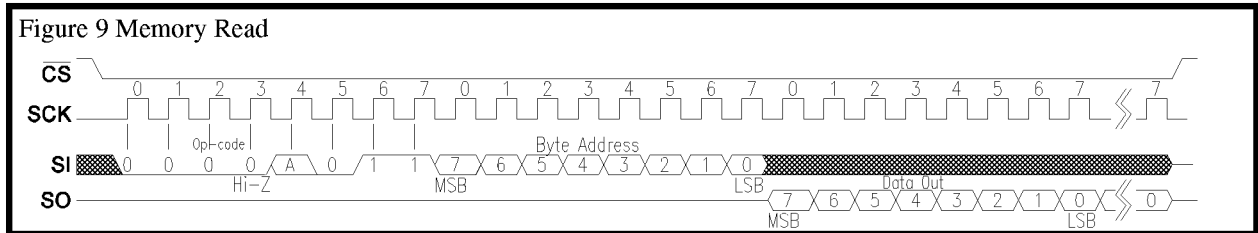
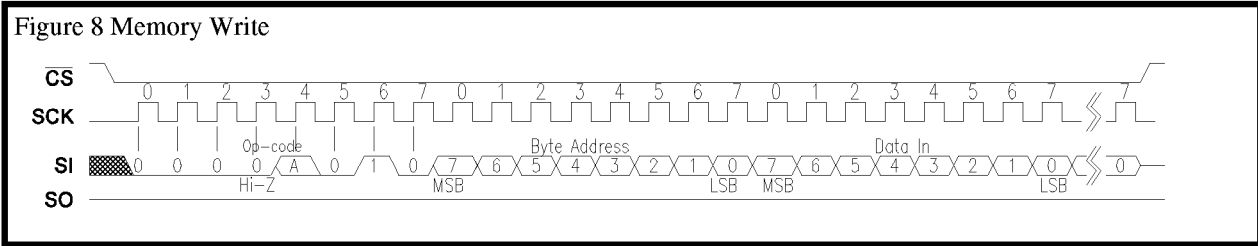

### Data Retention and Endurance

Data retention is specified in the electrical specifications below. For purposes of clarity, this section contrasts the retention and endurance of FRAM with EEPROM.

Like other nonvolatile memories such as EEPROM, FRAM data retention actually is a function of temperature. Much like other memories, this data sheet provides retention information at one commonly used temperature. A more complete characteristic is provided in a separate application note. The retention performance of FRAM is very comparable to EEPROM in its characteristics. However the effect of endurance cycles on retention is different.

A typical EEPROM has a write endurance specification that is fixed. Surpassing the specified level of cycles on an EEPROM usually leads to a hard memory failure. By contrast, the effect of increasing cycles on FRAM produces an increase in the soft error rate. That is, there is a higher likelihood of data loss but the memory continues to function properly.

While enough cycles would cause an apparent hard error, this is simply a very high soft error rate. This

characteristic makes it problematic to assign a fixed endurance specification. Users should review the characteristic curve for retention after endurance. Individual system design tradeoffs should dictate the target endurance level.

Endurance is a soft specification. Therefore the user may operate the device with different levels of endurance cycling for different portions of the memory. For example, critical data needing the highest reliability level could be stored in memory locations that receive comparatively few cycles. Data with shorter-term use could be located in an area receiving many more cycles. A scratchpad area, needing little if any retention can be cycled until there is virtually no retention capability remaining.

Internally, a FRAM operates with a read and restore mechanism similar to a DRAM. Therefore endurance cycles are applied for each access; read or write. The FRAM architecture is based on an array of rows and columns. Each access causes a cycle for an entire row. Therefore, data locations targeted for substantially differing numbers of cycles should not be located within the same row. In the FM25040 there are 64 rows each 64 bits wide. Each 8 bytes in the address mark the beginning of a new row.



## Applications

The versatility of FRAM technology fits into many diverse applications. Clearly the strength of higher write endurance and faster writes make FRAM superior to EEPROM in all but one-time programmable applications. The advantage is most obvious in data collection environments where writes are frequent and data must be nonvolatile.

The attributes of fast writes and high write endurance combine in many innovative ways. A short list of ideas is provided here.

1. Data collection. In applications where data is collected and saved, FRAM provides a superior alternative to other solutions. It is more cost effective than battery backup for SRAM and provides better write attributes than EEPROM.
2. Configuration. Any nonvolatile memory can retain a configuration. However if the configuration changes and power failure is a possibility, the higher write endurance of FRAM allows changes to be recorded without restriction. Any time the system state is altered, the change can be written. This avoids writing to memory on power down when the available time is short and power scarce.
3. High noise environments. Writing to EEPROM in a noisy environment can be challenging. When severe noise or power fluctuations are present, the long write time of EEPROM creates a window of vulnerability during which the write can be corrupted. The fast write of FRAM is complete within a

microsecond. This time is typically too short for noise or power fluctuation to disturb it.

4. Time to market. In a complex system, multiple software routines may need to access the nonvolatile memory. In this environment the time delay associated with programming EEPROM adds undue complexity to the software development. Each software routine must wait for complete programming before allowing access to the next routine. When time to market is critical, FRAM can eliminate this simple obstacle. As soon as a write is issued to the FM25040, it is effectively done -- no waiting.

5. RF/ID. In the area of contactless memory, FRAM provides an ideal solution. Since RF/ID memory is powered by an RF field, the long programming time and high current consumption needed to write EEPROM is unattractive. FRAM provides a superior solution. The FM25040 is suitable for multi-chip RF/ID products.

6. Maintenance tracking. In sophisticated systems, the operating history and system state during a failure is important knowledge. Maintenance can be expedited when this information has been recorded. Due to the high write endurance, FRAM makes an ideal system log. In addition, the convenient 2-wire interface of the FM25040 allows memory to be distributed throughout the system using minimal additional resources.

## Electrical Specifications

### Absolute Maximum Ratings

Description	Ratings
Ambient storage or operating temperature	-40°C to +85°C
Voltage on any pin with respect to ground	-1.0V to +7.0V
D.C. output current on any pin	5 mA
Lead temperature (Soldering, 10 seconds)	300° C

Stresses above those listed under Absolute Maximum Ratings may cause permanent damage to the device. This is a stress rating only, and the functional operation of the device at these or any other conditions above those listed in the operational section of this specification is not implied. Exposure to absolute maximum ratings conditions for extended periods may affect device reliability

### DC Operating Conditions TA = -40° C to +85° C, VCC = 4.5V to 5.5V unless otherwise specified

Symbol	Parameter	Min	Typ	Max	Units	Notes
VCC	Main Power Supply	4.5	5.0	5.5	V	1
ICC	VCC Supply Current @ SCK = 1.0 MHz		0.9	1.2	mA	2
ICC	VCC Supply Current @ SCK = 2.1 MHz		1.6	2.5	mA	2
ISB	Standby Current		1	10	μA	3
ILI	Input Leakage Current			10	μA	4
ILO	Output Leakage Current			10	μA	4
VIL	Input Low Voltage	-0.3		VCC x 0.3	V	1
VIH	Input High Voltage	VCC x 0.7		VCC + 0.5	V	1
VOL	Output Low Voltage @ IOL = 2 mA			0.4	V	1
VOH	Output High Voltage @ IOH = -1 mA	VCC-0.8			V	1
VHYS	Input Hysteresis	VCC x .05			V	1, 5

### Notes

1. Referenced to VSS.
2. SCK toggling between VCC-0.3V and VSS, other inputs VSS or VCC-0.3V
3. SCK = SI = /CS=VCC. All inputs VSS or VCC.
4. VIN or VOUT = VSS to VCC
5. This parameter is periodically sampled and not 100% tested.

AC Parameters TA = -40° C to + 85° C, VCC = 4.5V to 5.5V unless otherwise specified

Symbol	Parameter	Min	Max	Units
fCK	SCK Clock Frequency	0	2.1	MHz
tCH	Clock High Time	200		nS
tCL	Clock Low Time	200		nS
tCSU	Chip Select Setup	240		nS
tCSH	Chip Select Hold	240		nS
tOD	Output Disable		240	nS
tODV	Output Data Valid		200	nS
tOH	Output Hold	0		nS
tD	Deselect Time	240		nS
tR	Data Rise Time		2.0	μS
tF	Data Fall Time		2.0	μS
tH	Data Hold Time	100		nS
tSU	Data Setup Time	100		nS
tHS	/Hold Setup Time	90		nS
tHH	/Hold Hold Time	90		nS
tHZ	/Hold Low to Hi-Z		100	nS
tLZ	/Hold High to Data Active		100	nS

Notes

1. Rise and fall times measured between 10% and 90% of waveform.

Capacitance TA = 25° C , f=1.0 MHz, VCC = 5V

Symbol	Parameter	Max	Units	Notes
CO	Output capacitance (SDA)	8	pF	1
CI	Input capacitance	6	pF	1

Notes

1. This parameter is periodically sampled and not 100% tested.

AC Test Conditions

Input Pulse Levels VCC \* 0.1 to VCC \* 0.9  
 Input rise and fall times 10 nS  
 Input and output timing levels VCC\*0.5

Equivalent AC Load Circuit

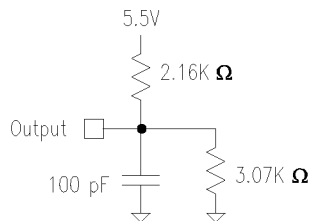

Serial Data Bus Timing

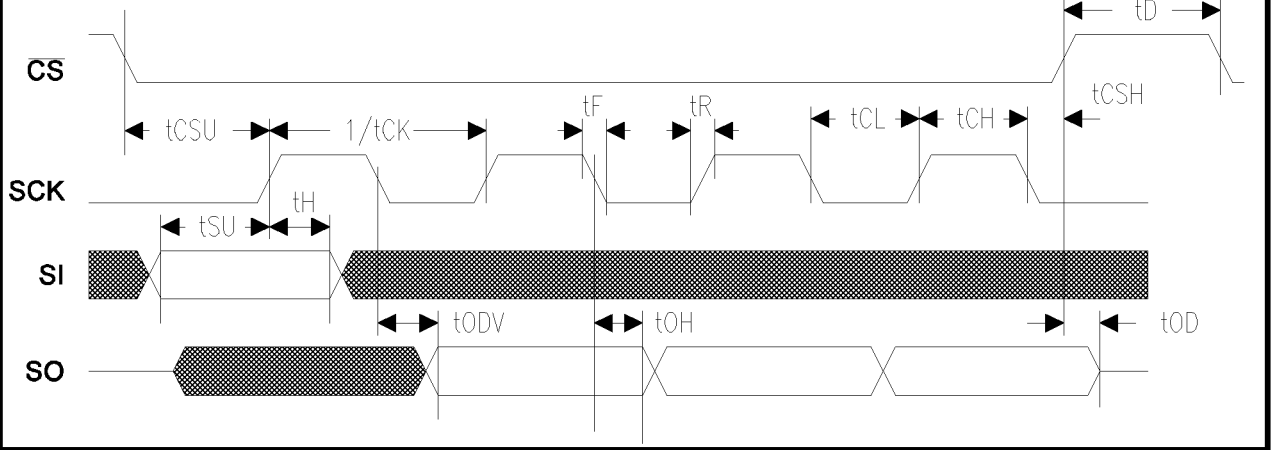

/Hold Timing

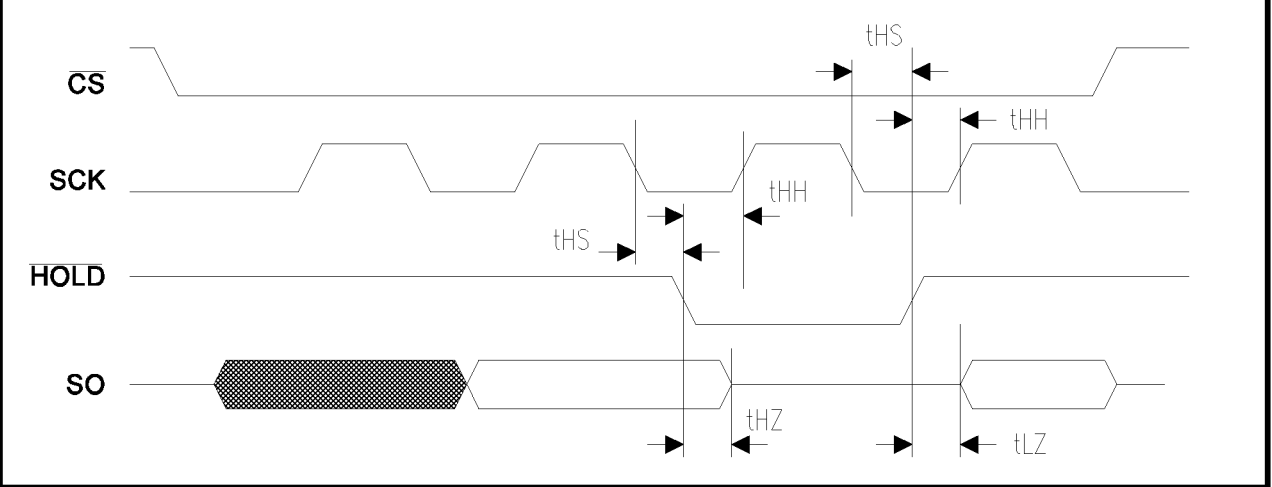

Data Retention TA = -40° C to + 85° C, VCC = 4.5V to 5.5V unless otherwise specified

Parameter	Min	Units	Notes
Data Retention	10	years	1,2

Notes

1. Data retention is specified at 55° C. The relationship between retention, temperature, and the associated reliability level is characterized in a separate reliability report.
2. Data retention reliability may be a function of cumulative read/write cycles as illustrated in the curve below.

Endurance

The impact of endurance cycles is to increase the soft error rate in data retention. The chart below illustrates the relationship. It shows the time to 0.1% parts with a data retention error. Also note that each read/write cycle affects an entire memory row for purposes of endurance.

Error Rate Versus Read/Write Cycles

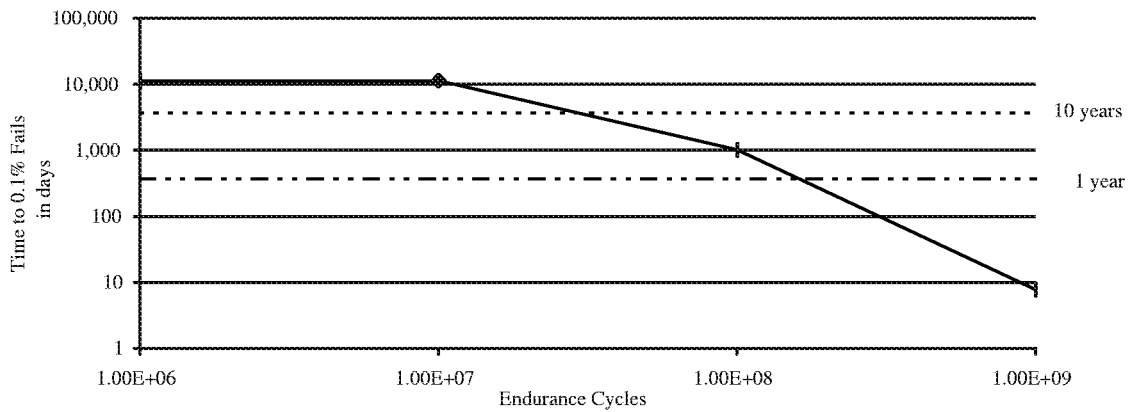

8-pin SOP JEDEC MS -012

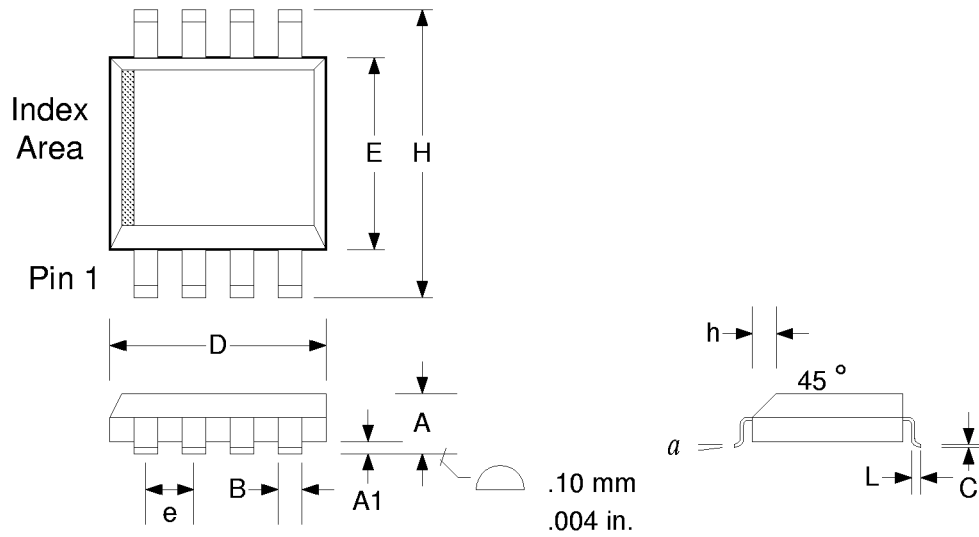

**Selected Dimensions**

Refer to JEDEC MS-012 for complete dimensions and notes.

Controlling dimensions is in millimeters. Conversions to inches are not exact.

Symbol	Dim	Min	Nom.	Max
A	mm in.	1.35 .053		1.75 .069
A1	mm in.	.10 .004		.25 .010
B	mm in.	.33 .013		.51 .020
C	mm in.	.19 .007		.25 .010
D	mm in.	4.80 .189		5.00 .197
E	mm in.	3.80 .150		4.00 .157
e	mm in.		1.27 BSC .050 BSC	
H	mm in.	5.80 .228		6.20 .244
h	mm in.	.25 .010		.50 .197
L	mm in.	.40 .016		1.27 .050
$\alpha$		0°		8°

8-pin DIP JEDEC MS -001

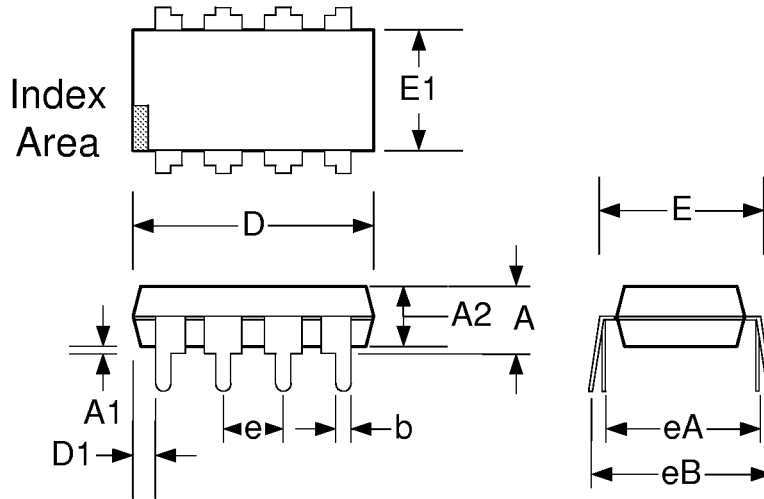

Selected Dimensions

Refer to JEDEC MS-001 for complete dimensions and notes.

Controlling dimensions is in inches. Conversions to millimeters are not exact.

Symbol	Dim	Min	Nom.	Max
A	in. mm			.210 5.33
A1	in. mm	0.015 .381		
A2	in. mm	0.115 2.92	0.130 3.30	0.195 4.95
b	in. mm	0.014 .356	0.018 .457	0.022 .508
D	in. mm	0.355 9.02	0.365 9.27	0.400 10.2
D1	in. mm	0.005 .127		
E	in. mm	0.300 7.62	0.310 7.87	0.325 8.26
E1	in. mm	0.240 6.10	0.250 6.35	0.280 7.11
e	in. mm		.100 BSC 2.54 BSC	
eA	in. mm		.300 BSC 7.62 BSC	
eB	in. mm			0.430 10.92
L	in. mm	0.115 2.92	0.130 3.30	0.150 3.81