

NMC27C128B High Speed Version

131,072-Bit (16k x 8) UV Erasable CMOS PROM

General Description

The NMC27C128B is a high-speed 128k UV erasable and electrically reprogrammable CMOS EPROM, ideally suited for applications where fast turnaround, pattern experimentation and low power consumption are important requirements.

The NMC27C128B is designed to operate with a single +5V power supply with $\pm 5\%$ or $\pm 10\%$ tolerance. The CMOS design allows the part to operate over extended and military temperature ranges.

The NMC27C128B is packaged in a 28-pin dual-in-line package with transparent lid. The transparent lid allows the user to expose the chip to ultraviolet light to erase the bit pattern. A new pattern can then be written electrically into the device by following the programming procedure.

This EPROM is fabricated with National's proprietary, time proven CMOS double-poly silicon gate technology which combines high performance and high density with low power consumption and excellent reliability.

Features

- Clock sense amps for fast access time down to 150 ns
- Low CMOS power consumption
 - Active Power: 110 mW max
 - Standby Power: 0.55 mW max
- Extended temperature range (NMC27C128BQE), -40°C to $+85^{\circ}\text{C}$, and military temperature range (NMC27C128BQM), -55°C to $+125^{\circ}\text{C}$ available
- Pin compatible with NMOS 128k EPROMs
- Fast and reliable programming—100 μs typical/byte
- Static operation—no clocks required
- TTL, CMOS compatible inputs/outputs
- TRI-STATE[®] output
- Optimum EPROM for total CMOS systems
- Manufacturer's identification code for automatic programming control
- High current CMOS level output drivers

Block Diagram

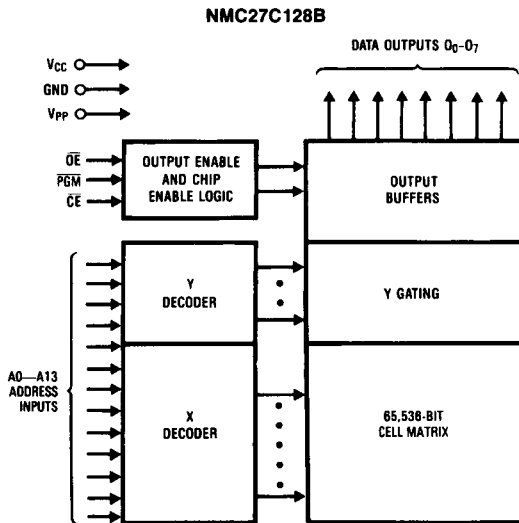

Pin Names

A0-A13	Addresses
$\overline{\text{CE}}$	Chip Enable
$\overline{\text{OE}}$	Output Enable
O ₀ -O ₇	Outputs
PGM	Program
NC	No Connect

TL/D/9689-1

Connection Diagrams

27C512	27C256	27C64	27C32	27C16
27512	27256	2764	2732	2716
A15	V _{PP}	V _{PP}		
A12	A12	A12		
A7	A7	A7	A7	A7
A6	A6	A6	A6	A6
A5	A5	A5	A5	A5
A4	A4	A4	A4	A4
A3	A3	A3	A3	A3
A2	A2	A2	A2	A2
A1	A1	A1	A1	A1
A0	A0	A0	A0	A0
O ₀	O ₀	O ₀	O ₀	O ₀
O ₁	O ₁	O ₁	O ₁	O ₁
O ₂	O ₂	O ₂	O ₂	O ₂
GND	GND	GND	GND	GND

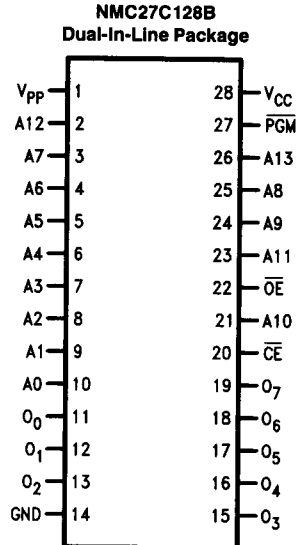

27C16	27C32	27C64	27C256	27C512
2716	2732	2764	27256	27512
		V _{CC}	V _{CC}	V _{CC}
		PGM	A14	A14
V _{CC}	V _{CC}	NC	A13	A13
A8	A8	A8	A8	A8
A9	A9	A9	A9	A9
V _{PP}	A11	A11	A11	A11
OE	OE/V _{PP}	OE	OE	OE/V _{PP}
A10	A10	A10	A10	A10
CE/PGM	CE	CE	CE/PGM	CE
O ₇	O ₇	O ₇	O ₇	O ₇
O ₆	O ₆	O ₆	O ₆	O ₆
O ₅	O ₅	O ₅	O ₅	O ₅
O ₄	O ₄	O ₄	O ₄	O ₄
O ₃	O ₃	O ₃	O ₃	O ₃

TL/D/9689-2

Note: Socket compatible EPROM pin configurations are shown in the blocks adjacent to the NMC27C128B pins.

Order Number NMC27C128BQ
See NS Package Number J28AQ

Commercial Temp Range (0°C to +70°C)
V_{CC} = 5V ± 10%

Commercial Temp Range (0°C to +70°C)
V_{CC} = 5V ± 5%

Parameter/Order Number	Access Time (ns)
NMC27C128BQ150	150
NMC27C128BQ200	200
NMC27C128BQ250	250

Parameter/Order Number	Access Time (ns)
NMC27C128BQ15	150
NMC27C128BQ20	200
NMC27C128BQ25	250

Extended Temp Range (-40°C to +85°C)
V_{CC} = 5V ± 10%

Military Temp Range (-55°C to +125°C)
V_{CC} = 5V ± 10%

Parameter/Order Number	Access Time (ns)
NMC27C128BQE150	150
NMC27C128BQE200	200

Parameter/Order Number	Access Time (ns)
NMC27C128BQM150	150
NMC27C128BQM200	200

NOTE: For plastic DIP and surface mount PLCC package requirements please refer to NMC27C128BN datasheet.

COMMERCIAL TEMPERATURE RANGE

Absolute Maximum Ratings (Note 1)

Temperature Under Bias	-10°C to +80°C
Storage Temperature	-65°C to +150°C
All Input Voltages except A9 with Respect to Ground (Note 10)	+6.5V to -0.6V
All Output Voltages with Respect to Ground (Note 10)	$V_{CC} + 1.0V$ to $GND - 0.6V$
V_{PP} Supply Voltage and A9 with Respect to Ground During Programming	+14.0V to -0.6V
V_{CC} Supply Voltage with Respect to Ground	+7.0V to -0.6V

Power Dissipation	1.0W
Lead Temperature (Soldering, 10 sec.)	300°C
ESD Rating (Mil Spec 883C, Method 3015.2)	2000V

Operating Conditions (Note 7)

Temperature Range	0°C to +70°C
V_{CC} Power Supply	+5V ± 10%
NMC27C128BQ150, 200, 250	
NMC27C128BQ15, 20, 25	±5V ±5%

READ OPERATION

DC Electrical Characteristics

Symbol	Parameter	Conditions	Min	Typ	Max	Units
I_{LI}	Input Load Current	$V_{IN} = V_{CC}$ or GND		0.01	1	μA
I_{LO}	Output Leakage Current	$V_{OUT} = V_{CC}$ or GND, $\overline{CE} = V_{IH}$		0.01	1	μA
I_{CC1} (Note 9)	V_{CC} Current (Active) TTL Inputs	$\overline{CE} = V_{IL}$, $f = 5$ MHz Inputs = V_{IH} or V_{IL} , I/O = 0 mA		10	30	mA
I_{CC2} (Note 9)	V_{CC} Current (Active) CMOS Inputs	$\overline{CE} = GND$, $f = 5$ MHz Inputs = V_{CC} or GND, I/O = 0 mA		8	20	mA
I_{CCSB1}	V_{CC} Current (Standby) TTL Inputs	$\overline{CE} = V_{IH}$		0.1	1	mA
I_{CCSB2}	V_{CC} Current (Standby) CMOS Inputs	$\overline{CE} = V_{CC}$		0.5	100	μA
I_{PP}	V_{PP} Load Current	$V_{PP} = V_{CC}$			10	μA
V_{IL}	Input Low Voltage		-0.2		0.8	V
V_{IH}	Input High Voltage		2.0		$V_{CC} + 1$	V
V_{OL1}	Output Low Voltage	$I_{OL} = 2.1$ mA			0.40	V
V_{OH1}	Output High Voltage	$I_{OH} = -2.5$ mA	3.5			V
V_{OL2}	Output Low Voltage	$I_{OL} = 10$ μA			0.1	V
V_{OH2}	Output High Voltage	$I_{OH} = -10$ μA	$V_{CC} - 0.1$			V

AC Electrical Characteristics

Symbol	Parameter	Conditions	NMC27C128B						Units
			Q15, Q150		Q20, Q200		Q25, Q250		
			Min	Max	Min	Max	Min	Max	
t_{ACC}	Address to Output Delay	$\overline{CE} = \overline{OE} = V_{IL}$ $PGM = V_{IH}$		150		200		250	ns
t_{CE}	\overline{CE} to Output Delay	$\overline{OE} = V_{IL}$, $PGM = V_{IH}$		150		200		250	ns
t_{OE}	\overline{OE} to Output Delay	$\overline{CE} = V_{IL}$, $PGM = V_{IH}$		60		75		100	ns
t_{DF}	\overline{OE} High to Output Float	$\overline{CE} = V_{IL}$, $PGM = V_{IH}$	0	50	0	55	0	60	ns
t_{CF}	\overline{CE} High to Output Float	$\overline{OE} = V_{IL}$, $PGM = V_{IH}$	0	50	0	55	0	60	ns
t_{OH}	Output Hold from Addresses, \overline{CE} or \overline{OE} , Whichever Occurred First	$\overline{CE} = \overline{OE} = V_{IL}$ $PGM = V_{IH}$	0		0		0		ns

MILITARY AND EXTENDED TEMPERATURE RANGE

Absolute Maximum Ratings (Note 1)

If Military/Aerospace specified devices are required, please contact the National Semiconductor Sales Office/Distributors for availability and specifications.

Temperature Under Bias	Operating Temp. Range	
Storage Temperature	-65°C to +150°C	
All Input Voltages except A9 with Respect to Ground (Note 10)	+6.5V to -0.6V	
All Output Voltages with Respect to Ground (Note 10)	$V_{CC} + 1.0V$ to $GND - 0.6V$	
V_{PP} Supply Voltage and A9 with Respect to Ground During Programming	+14.0V to -0.6V	

V_{CC} Supply Voltage with Respect to Ground	+7.0V to -0.6V
Power Dissipation	1.0W
Lead Temperature (Soldering, 10 sec.)	300°C
ESD Rating (Mil Spec 883C, Method 3015.2)	2000V

Operating Conditions (Note 7)

Temperature Range	-40°C to +85°C
NMC27C128BQE150, 200	-55°C to +125°C
NMC27C128BQM150, 200	
V_{CC} Power Supply	+5V ±10%

READ OPERATION

DC Electrical Characteristics

Symbol	Parameter	Conditions	Min	Typ	Max	Units
I_{LI}	Input Load Current	$V_{IN} = V_{CC}$ or GND			10	μA
I_{LO}	Output Leakage Current	$V_{OUT} = V_{CC}$ or GND, $\overline{CE} = V_{IH}$			10	μA
I_{CC1} (Note 9)	V_{CC} Current (Active) TTL Inputs	$\overline{CE} = V_{IL}$, $f = 5$ MHz Inputs = V_{IH} or V_{IL} , I/O = 0 mA		10	30	mA
I_{CC2} (Note 9)	V_{CC} Current (Active) CMOS Inputs	$\overline{CE} = GND$, $f = 5$ MHz Inputs = V_{CC} or GND, I/O = 0 mA		8	20	mA
I_{CCSB1}	V_{CC} Current (Standby) TTL Inputs	$\overline{CE} = V_{IH}$		0.1	1	mA
I_{CCSB2}	V_{CC} Current (Standby) CMOS Inputs	$\overline{CE} = V_{CC}$		0.5	100	μA
I_{PP}	V_{PP} Load Current	$V_{PP} = V_{CC}$			10	μA
V_{IL}	Input Low Voltage		-0.2		0.8	V
V_{IH}	Input High Voltage		2.0		$V_{CC} + 1$	V
V_{OL1}	Output Low Voltage	$I_{OL} = 2.1$ mA			0.40	V
V_{OH1}	Output High Voltage	$I_{OH} = -1.6$ mA	3.5			V
V_{OL2}	Output Low Voltage	$I_{OL} = 10$ μA			0.1	V
V_{OH2}	Output High Voltage	$I_{OH} = -10$ μA	$V_{CC} - 0.1$			V

AC Electrical Characteristics

Symbol	Parameter	Conditions	NMC27C128BQ				Units
			E150, M150		E200, M200		
			Min	Max	Min	Max	
t_{ACC}	Address to Output Delay	$\overline{CE} = \overline{OE} = V_{IL}$ $PGM = V_{IH}$		150		200	ns
t_{CE}	\overline{CE} to Output Delay	$\overline{OE} = V_{IL}$, $PGM = V_{IH}$		150		200	ns
t_{OE}	\overline{OE} to Output Delay	$\overline{CE} = V_{IL}$, $PGM = V_{IH}$		60		75	ns
t_{DF}	\overline{OE} High to Output Float	$\overline{CE} = V_{IL}$, $PGM = V_{IH}$	0	50	0	55	ns
t_{CF}	\overline{CE} High to Output Float	$\overline{OE} = V_{IL}$, $PGM = V_{IH}$	0	50	0	55	ns
t_{OH}	Output Hold from Addresses, \overline{CE} or \overline{OE} , Whichever Occurred First	$\overline{CE} = \overline{OE} = V_{IL}$ $PGM = V_{IH}$	0		0		ns

1

Capacitance $T_A = +25^\circ\text{C}$, $f = 1\text{ MHz}$ (Note 2)

Symbol	Parameter	Conditions	Typ	Max	Units
C_{IN}	Input Capacitance	$V_{IN} = 0\text{V}$	6	12	pF
C_{OUT}	Output Capacitance	$V_{OUT} = 0\text{V}$	9	12	pF

AC Test Conditions

Output Load	1 TTL Gate and $C_L = 100\text{ pF}$ (Note 8)	Timing Measurement Reference Level	
Input Rise and Fall Times	$\leq 5\text{ ns}$	Inputs	0.8V and 2V
Input Pulse Levels	0.45V to 2.4V	Outputs	0.8V and 2V

AC Waveforms (Notes 6, 7 & 9)

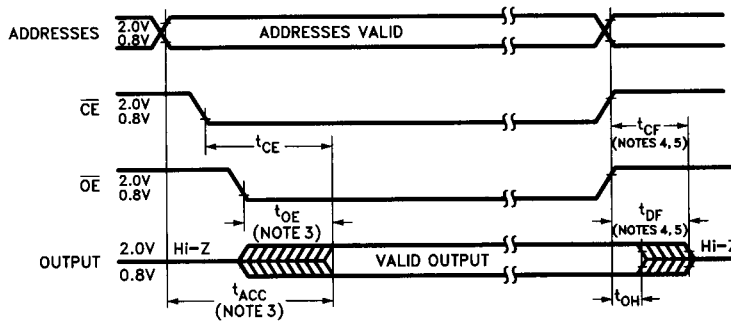

TL/D/9689-3

Note 1: Stresses above those listed under "Absolute Maximum Ratings" may cause permanent damage to the device. This is a stress rating only and functional operation of the device at these or any other conditions above those indicated in the operational sections of this specification is not implied. Exposure to absolute maximum rating conditions for extended periods may affect device reliability.

Note 2: This parameter is only sampled and is not 100% tested.

Note 3: \overline{OE} may be delayed up to $t_{ACC} - t_{OE}$ after the falling edge of \overline{CE} without impacting t_{ACC} .

Note 4: The t_{DF} and t_{CF} compare level is determined as follows:

- High to TRI-STATE, the measured V_{OH1} (DC) $- 0.10\text{V}$;
- Low to TRI-STATE, the measured V_{OL1} (DC) $+ 0.10\text{V}$.

Note 5: TRI-STATE may be attained using \overline{OE} or \overline{CE} .

Note 6: The power switching characteristics of EPROMs require careful device decoupling. It is recommended that at least a $0.1\text{ }\mu\text{F}$ ceramic capacitor be used on every device between V_{CC} and GND.

Note 7: The outputs must be restricted to $V_{CC} + 1.0\text{V}$ to avoid latch-up and device damage.

Note 8: 1 TTL Gate: $I_{OL} = 1.6\text{ mA}$, $I_{OH} = -400\text{ }\mu\text{A}$.
 C_L : 100 pF includes fixture capacitance.

Note 9: V_{PP} may be connected to V_{CC} except during programming.

Note 10: Inputs and outputs can undershoot to -2.0V for 20 ns Max.

Programming Characteristics (Notes 1, 2, 3 & 4)

Symbol	Parameter	Conditions	Min	Typ	Max	Units
t_{AS}	Address Setup Time		1			μs
t_{OES}	\overline{OE} Setup Time		1			μs
t_{CES}	\overline{CE} Setup Time	$\overline{OE} = V_{IH}$	1			μs
t_{DS}	Data Setup Time		1			μs
t_{VPS}	V_{PP} Setup Time		1			μs
t_{VCS}	V_{CC} Setup Time		1			μs
t_{AH}	Address Hold Time		0			μs
t_{DH}	Data Hold Time		1			μs
t_{DF}	Output Enable to Output Float Delay	$\overline{CE} = V_{IL}$	0		60	ns
t_{PW}	Program Pulse Width		95	100	105	μs
t_{OE}	Data Valid from \overline{OE}	$\overline{CE} = V_{IL}$			100	ns
I_{PP}	V_{PP} Supply Current During Programming Pulse	$\overline{CE} = V_{IL}$ $PGM = V_{IL}$			30	mA
I_{CC}	V_{CC} Supply Current				10	mA
T_A	Temperature Ambient		20	25	30	$^{\circ}\text{C}$
V_{CC}	Power Supply Voltage		6.0	6.25	6.5	V
V_{PP}	Programming Supply Voltage		12.5	12.75	13.0	V
t_{FR}	Input Rise, Fall Time		5			ns
V_{IL}	Input Low Voltage			0.0	0.45	V
V_{IH}	Input High Voltage		2.4	4.0		V
t_{IN}	Input Timing Reference Voltage		0.8	1.5	2.0	V
t_{OUT}	Output Timing Reference Voltage		0.8	1.5	2.0	V

Programming Waveforms (Note 3)

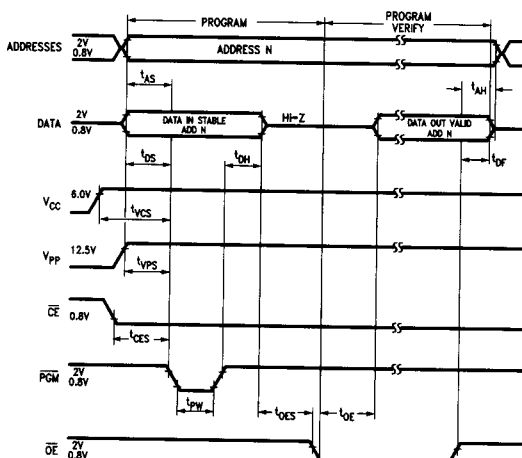

TL/D/9689-4

Note 1: National's standard product warranty applies to devices programmed to specifications described herein.

Note 2: V_{CC} must be applied simultaneously or before V_{PP} and removed simultaneously or after V_{PP} . The EPROM must not be inserted into or removed from a board with voltage applied to V_{PP} or V_{CC} .

Note 3: The maximum absolute allowable voltage which may be applied to the V_{PP} pin during programming is 14V. Care must be taken when switching the V_{PP} supply to prevent any overshoot from exceeding this 14V maximum specification. At least a 0.1 μF capacitor is required across V_{PP} , V_{CC} to GND to suppress spurious voltage transients which may damage the device.

Note 4: Programming and program verify are tested with the fast Program Algorithm, at typical power supply voltages and timings.

Fast Programming Algorithm Flow Chart (Note 4)

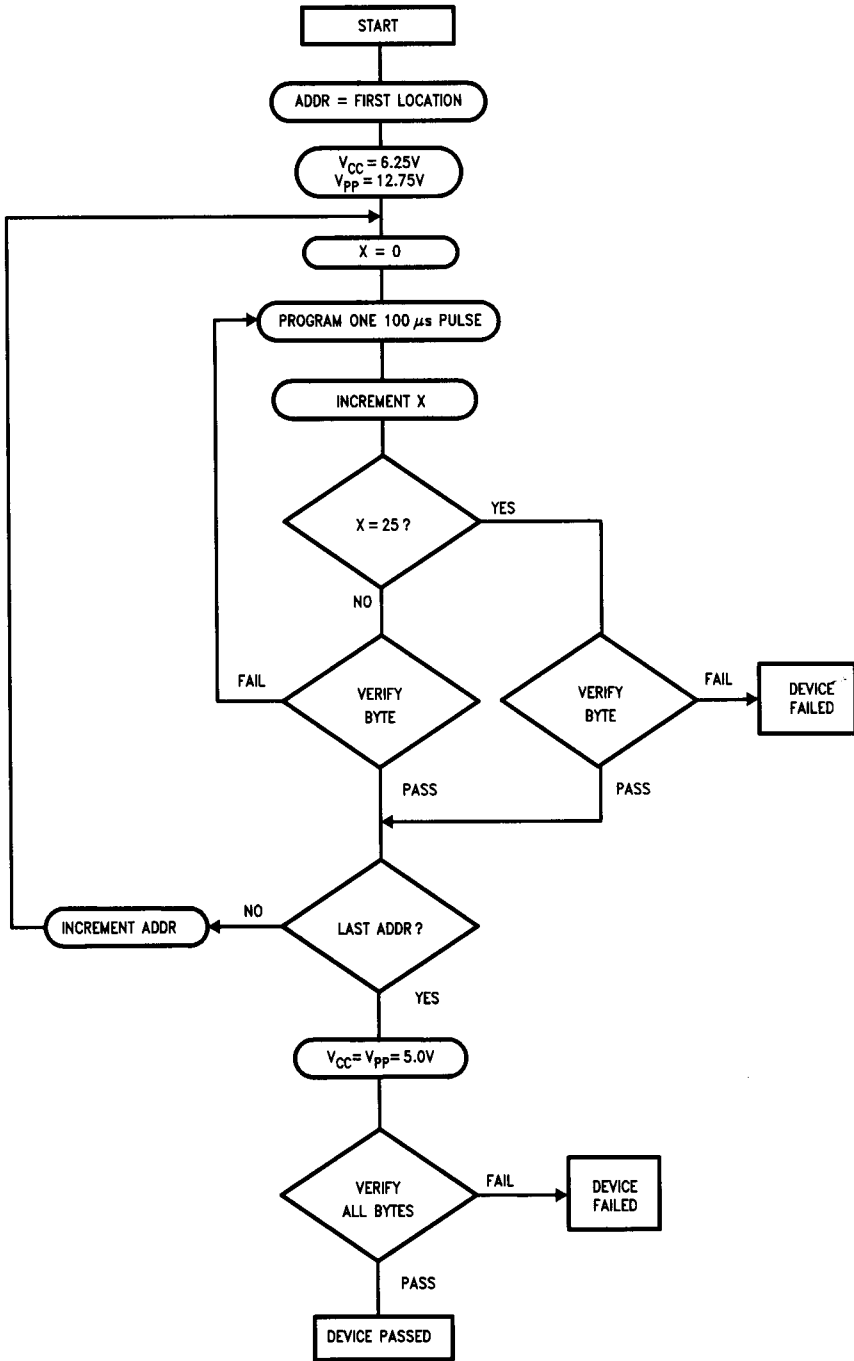

FIGURE 1

Interactive Programming Algorithm Flow Chart (Note 4)

NMC27C128B

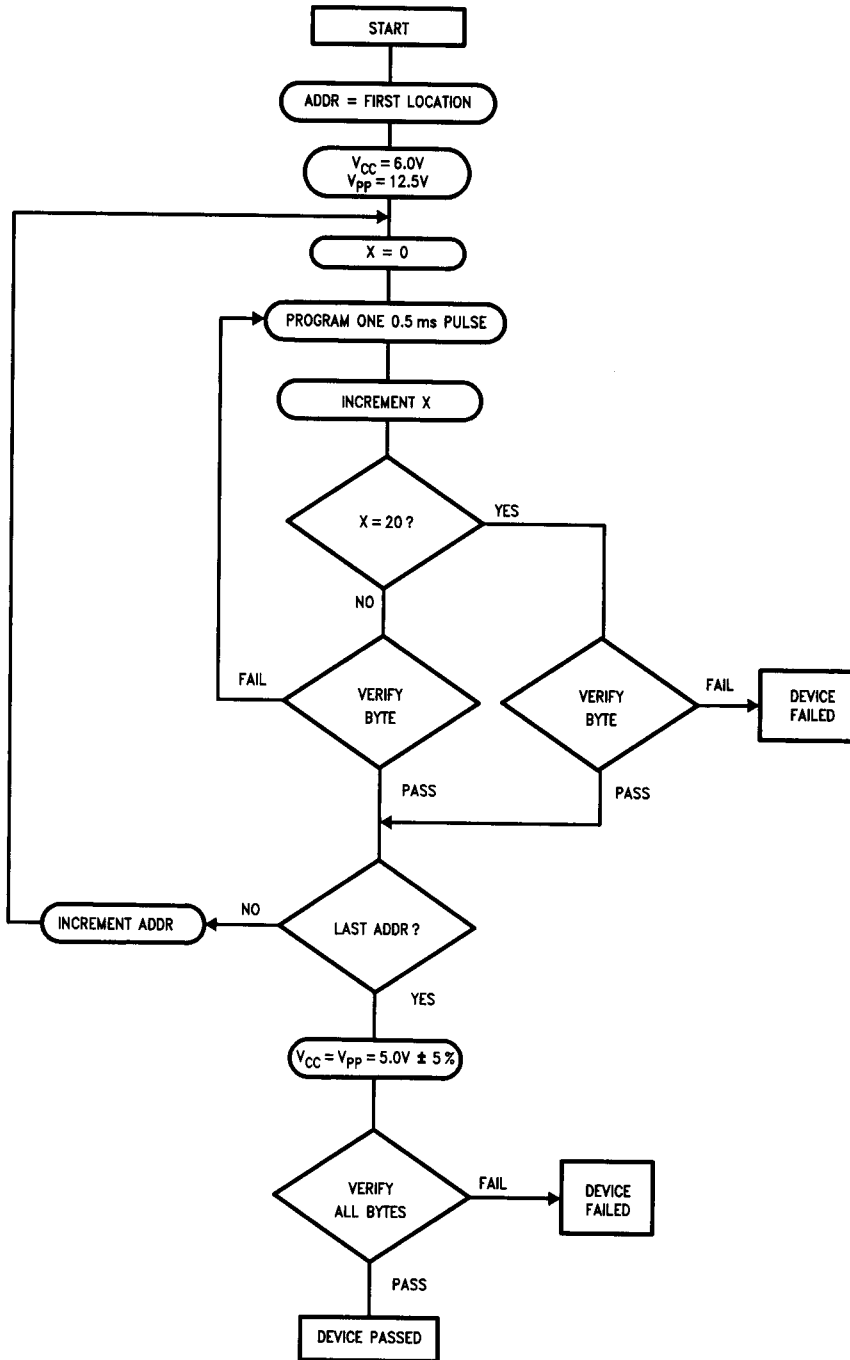

FIGURE 2

TL/D/9689-6

Functional Description

DEVICE OPERATION

The six modes of operation of the NMC27C128B are listed in Table I. It should be noted that all inputs for the six modes are at TTL levels. The power supplies required are V_{CC} and V_{pp} . The V_{pp} power supply must be at 12.75V during the three programming modes, and must be at V_{CC} in the other three modes. The V_{CC} power supply must be at 6.25V during the three programming modes, and at 5V in the other three modes.

Read Mode

The NMC27C128B has two control functions, both of which must be logically active in order to obtain data at the outputs. Chip Enable (\overline{CE}) is the power control and should be used for device selection. Output Enable (\overline{OE}) is the output control and should be used to gate data to the output pins, independent of device selection. The programming pin (PGM) should be at V_{IH} except during programming. Assuming that addresses are stable, address access time (t_{ACC}) is equal to the delay from \overline{CE} to output (t_{OE}). Data is available at the outputs t_{OE} after the falling edge of \overline{OE} , assuming that \overline{CE} has been low and addresses have been stable for at least $t_{ACC} - t_{OE}$.

The sense amps are clocked for fast access time. V_{CC} should therefore be maintained at operating voltage during read and verify. If V_{CC} temporarily drops below the spec. voltage (but not to ground) an address transition must be performed after the drop to insure proper output data.

Standby Mode

The NMC27C128B has a standby mode which reduces the active power dissipation by over 99%, from 110 mW to 0.55 mW. The NMC27C128B is placed in the standby mode by applying a CMOS high signal to the \overline{CE} input. When in standby mode, the outputs are in a high impedance state, independent of the \overline{OE} input.

Output OR-Tying

Because NMC27C128Bs are usually used in larger memory arrays, National has provided a 2-line control function that accommodates this use of multiple memory connections. The 2-line control function allows for:

- the lowest possible memory power dissipation, and
- complete assurance that output bus contention will not occur.

To most efficiently use these two control lines, it is recommended that \overline{CE} (pin 20) be decoded and used as the pri-

mary device selecting function, while \overline{OE} (pin 22) be made a common connection to all devices in the array and connected to the READ line from the system control bus. This assures that all deselected memory devices are in their low power standby modes and that the output pins are active only when data is desired from a particular memory device.

Programming

CAUTION: Exceeding 14V on pin 1 (V_{pp}) will damage the NMC27C128B.

Initially, and after each erasure, all bits of the NMC27C128B are in the "1" state. Data is introduced by selectively programming "0s" into the desired bit locations. Although only "0s" will be programmed, both "1s" and "0s" can be presented in the data word. The only way to change a "0" to a "1" is by ultraviolet light erasure.

The NMC27C128B is in the programming mode when the V_{pp} power supply is at 12.75V and \overline{OE} is at V_{IH} . It is required that at least a 0.1 μ F capacitor be placed across V_{pp} , V_{CC} to ground to suppress spurious voltage transients which may damage the device. The data to be programmed is applied 8 bits in parallel to the data output pins. The levels required for the address and data inputs are TTL.

For programming, \overline{CE} should be kept TTL low at all times while V_{pp} is kept at 12.75V

When the address and data are stable, an active low, TTL program pulse is applied to the PGM input. A program pulse must be applied at each address location to be programmed. The NMC27C128B is programmed with the Fast Programming Algorithm shown in Figure 1. Each Address is programmed with a series of 100 μ s pulses until it verifies good, up to a maximum of 25 pulses. Most memory cells will program with a single 100 μ s pulse.

Note: Some programmer manufacturers due to equipment limitation may offer interactive program Algorithm (shown in Figure 2).

The NMC27C128B must not be programmed with a DC signal applied to the PGM input.

Programming multiple NMC27C128Bs in parallel with the same data can be easily accomplished due to the simplicity of the programming requirements. Like inputs of the paralleled NMC27C128Bs may be connected together when they are programmed with the same data. A low level TTL pulse applied to the PGM input programs the paralleled NMC27C128Bs.

TABLE I. Mode Selection

Mode	Pins	\overline{CE} (20)	\overline{OE} (22)	PGM (27)	V_{pp} (1)	V_{CC} (28)	Outputs (11-13, 15-19)
Read		V_{IL}	V_{IL}	V_{IH}	V_{CC}	5V	D_{OUT}
Standby		V_{IH}	Don't Care	Don't Care	V_{CC}	5V	Hi-Z
Output Disable		Don't Care	V_{IH}	V_{IH}	V_{CC}	5V	Hi-Z
Program		V_{IL}	V_{IH}	V_{IL}	12.75V	6.25V	D_{IN}
Program Verify		V_{IL}	V_{IL}	V_{IH}	12.75V	6.25V	D_{OUT}
Program Inhibit		V_{IH}	Don't Care	Don't Care	12.75V	6.25V	Hi-Z

Functional Description (Continued)

Program Inhibit

Programming multiple NMC27C128s in parallel with different data is also easily accomplished. Except for \overline{CE} all like inputs (including \overline{OE} and \overline{PGM}) of the parallel NMC27C128Bs may be common. A TTL low level program pulse applied to an NMC27C128B's \overline{PGM} input with \overline{CE} at V_{IL} and V_{PP} at 12.75V will program that NMC27C128B. A TTL high level \overline{CE} input inhibits the other NMC27C128Bs from being programmed.

Program Verify

A verify should be performed on the programmed bits to determine whether they were correctly programmed. The verify may be performed with V_{PP} at 12.75V. V_{PP} must be at V_{CC} except during programming and program verify.

MANUFACTURER'S IDENTIFICATION CODE

The NMC27C128B has a manufacturer's identification code to aid in programming. The code, shown in Table II, is two bytes wide and is stored in a ROM configuration on the chip. It identifies the manufacturer and the device type. The code for the NMC27C128B is "8F83", where "8F" designates that it is made by National Semiconductor, and "83" designates a 128k part.

The code is accessed by applying 12.0V \pm 0.5V to address pin A9. Addresses A1–A8, A10–A13, \overline{CE} , and \overline{OE} are held at V_{IL} . Address A0 is held at V_{IL} for the manufacturer's code, and at V_{IH} for the device code. The code is read out on the 8 data pins. Proper code access is only guaranteed at 25°C \pm 5°C.

The primary purpose of the manufacturer's identification code is automatic programming control. When the device is inserted in an EPROM programmer socket, the programmer reads the code and then automatically calls up the specific programming algorithm for the part. This automatic programming control is only possible with programmers which have the capability of reading the code.

ERASURE CHARACTERISTICS

The erasure characteristics of the NMC27C128B are such that erasure begins to occur when exposed to light with wavelengths shorter than approximately 4000 Angstroms (\AA). It should be noted that sunlight and certain types of fluorescent lamps have wavelengths in the 3000 \AA –4000 \AA range.

After programming opaque labels should be placed over the NMC27C128B's window to prevent unintentional erasure. Covering the window will also prevent temporary functional failure due to the generation of photo currents.

The recommended erasure procedure for the NMC27C128B is exposure to short wave ultraviolet light which has a wavelength of 2537 Angstroms (\AA). The integrated dose (i.e., UV intensity \times exposure time) for erasure should be a minimum of 15W-sec/cm².

The NMC27C128B should be placed within 1 inch of the lamp tubes during erasure. Some lamps have a filter on their tubes which should be removed before erasure. Table III shows the minimum NMC27C128B erasure time for various light intensities.

An erasure system should be calibrated periodically. The distance from lamp to unit should be maintained at one inch. The erasure time increases as the square of the distance. (If distance is doubled the erasure time increases by a factor of 4.) Lamps lose intensity as they age. When a lamp is changed, the distance has changed or the lamp has aged, the system should be checked to make certain full erasure is occurring. Incomplete erasure will cause symptoms that can be misleading. Programmers, components, and even system designs have been erroneously suspected when incomplete erasure was the problem.

SYSTEM CONSIDERATION

The power switching characteristics of this device require careful decoupling of the devices. The supply current, I_{CC} , has three segments that are of interest to the system designer—the standby current level, the active current level, and the transient current peaks that are produced by voltage transitions on input pins. The magnitude of these transient current peaks is dependent on the output capacitance loading of the device. The associated V_{CC} transient voltage peaks can be suppressed by properly selected decoupling capacitors. It is recommended that at least a 0.1 μ F ceramic capacitor be used on every device between V_{CC} and GND. This should be a high frequency capacitor of low inherent inductance. In addition, at least a 4.7 μ F electrolytic capacitor should be used between V_{CC} and GND for each eight devices. The bulk capacitor should be located near where the power supply is connected to the array. The purpose of the bulk capacitor is to overcome the voltage drop caused by the inductive effects of the PC board traces.

TABLE II. Manufacturer's Identification Code

Pins	A0 (10)	O ₇ (19)	O ₆ (18)	O ₅ (17)	O ₄ (16)	O ₃ (15)	O ₂ (13)	O ₁ (12)	O ₀ (11)	Hex Data
Manufacturer Code	V_{IL}	1	0	0	0	1	1	1	1	8F
Device Code	V_{IH}	1	0	0	0	0	0	1	1	83

TABLE III. Minimum NMC27C128B Erasure Time

Light Intensity (μ W/cm ²)	Erasure Time (Minutes)
15,000	20
10,000	25
5,000	50