

4MEGA BIT (262,144 WORD × 16BIT / 524,288 WORD × 8BIT)
CMOS U.V. ERASABLE AND ELECTRICALLY PROGRAMMABLE READ ONLY MEMORY

DESCRIPTION

The TC574200D is a 4,194,304 bit CMOS ultraviolet light erasable and electrically programmable read only memory. It is organized as 256K words of 16 bit or 512K words of 8 bit. The TC574200D is compatible with 40 pin 4M bit Mask ROM. This product is packed in 40 pin standard cerdip package. The TC574200D is fabricated with the CMOS technology. Advanced circuit techniques provide both high speed and low power features with access time of 100ns/120ns/150ns and a maximum operating current of 70mA/10MHz. The programming time of the TC574200D except overhead times of EPROM programmer is only 28 seconds by using the high speed programming algorithm.

FEATURES

- Peripheral circuit : CMOS
- Memory cell : NMOS
- Low power
- Standby dissipation : 100µA
- Fast access time
- Full static operation
- Input and output TTL compatible
- Three state output
- High speed programming operation : tpw 50µs
- 4M MROM compatible pinout : TC534200P
- Standard 40 pin DIP cerdip package : WDIP40-P-600B

	- 10	- 120	- 150
V _{CC}	5V ± 5%	5V ± 10%	
Temp	0°C ~ 70°C		
T _{acc}	100ns	120ns	150ns

- 10 satisfies characteristics of - 120.

- Single 5V power supply

PIN CONNECTION

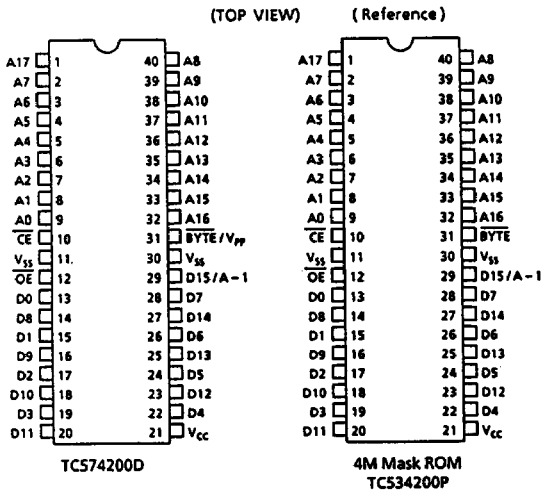

PIN NAMES

A0~A17	Address Input
D0~D14	Output (Input)
CE	Chip Enable Input
OE	Output Enable Input
D15/A-1	Output (Input) / Address Input
BYTE/V _{pp}	Word, Byte select input / Program Supply Voltage
V _{CC}	V _{CC} Supply Voltage
V _{SS}	Ground

TC574200D-10, TC574200D-120 TC574200D-150

BLOCK DIAGRAM

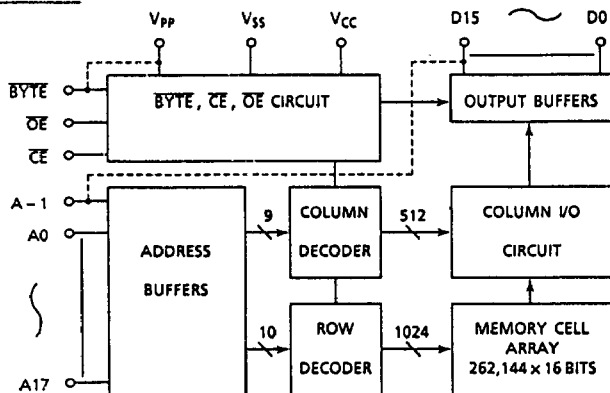

MODE SELECTION

MODE	PINS	\overline{CE}	\overline{OE}	BYTE / V_{EP}	V_{CC}	D0~D7	D8~D14	D15 / A-1	Power
Read (16 Bit)		L	L	H	5V	Data Out			Active
Read (Lower 8 Bit)		L	L	L		Data Out (Lower 8 Bit)	High Impedance	L	
Read (Upper 8 Bit)		L	L	L		Data Out (Upper 8 Bit)	High Impedance	H	
Output Deselect		L	H	H		High Impedance			
				L		High Impedance	*		
Standby		H	*	H	High Impedance			Standby	
Program		L	H	H	Data In				
Program Inhibit		H	H	12.5V	6.25V	High Impedance			Active
Program Verify		*	L	L		Data Out			

Note: H = V_{IH} , L = V_{IL} , * = V_{IH} or V_{IL}

MAXIMUM RATINGS

SYMBOL	ITEM	RATING	UNIT
V_{CC}	V_{CC} Power Supply Voltage	-0.6~7.0	V
V_{PP}	Program Supply Voltage	-0.6~14.0	V
V_{IN}	Input Voltage	-0.6~7.0	V
$V_{IN}(A9)$	Input Voltage (A9)	-0.6~13.5	V
$V_{I/O}$	Input/Output Voltage	-0.6~ $V_{CC}+0.5$	V
P_D	Power Dissipation	1.5	W
T_{SOLDER}	Soldering Temperature · Time	260·10	°C · sec
T_{STRG}	Storage Temperature	-65~150	°C
T_{OPR}	Operating Temperature	0~70	°C

READ OPERATION

D.C. RECOMMENDED OPERATING CONDITIONS

SYMBOL	PARAMETER	TC574000D - 10	TC574000D - 120 / 150
V _{IH}	Input High Voltage	2.2V~V _{CC} +0.3	2.2V~V _{CC} +0.3
V _{IL}	Input Low Voltage	-0.3V~0.8V	-0.3V~0.8V
V _{CC}	V _{CC} Power Supply Voltage	5V ± 5%	5V ± 10%

D.C. AND OPERATING CHARACTERISTICS (Ta = 0~70°C)

SYMBOL	PARAMETER	TEST CONDITION	MIN.	TYP.	MAX.	UNIT
I _{LI}	Input Current	V _{IN} = 0V~V _{CC}	-	-	± 10	μA
I _{CCO1}	Operating Current	CE = 0V I _{OUT} = 0mA f = 10MHz	-	-	70	mA
		CE = 0V I _{OUT} = 0mA f = 8.3MHz	-	-	60	mA
		CE = 0V I _{OUT} = 0mA f = 1MHz	-	-	30	mA
I _{CCS1}	Standby Current	CE = V _{IH}	-	-	1	mA
		I _{CCS2}	CE = V _{CC} - 0.2V	-	-	100
V _{OH}	Output High Voltage	I _{OH} = -400μA	2.4	-	-	V
V _{OL}	Output Low Voltage	I _{OL} = 2.1mA	-	-	0.4	V
I _{PP1}	V _{PP} Current	V _{PP} = 0V~V _{CC} + 0.6V	-	-	± 10	μA
I _{LO}	Output Leakage Current	V _{OUT} = 0.4V~V _{CC}	-	-	± 10	μA

A.C. CHARACTERISTICS (Ta = 0~70°C)

SYMBOL	PARAMETER	- 10		- 120		- 150		UNIT
		MIN.	MAX.	MIN.	MAX.	MIN.	MAX.	
t _{ACC}	Address Access Time	-	100	-	120	-	150	ns
t _{CE}	CE to Output Valid	-	100	-	120	-	150	ns
t _{OE}	OE to Output Valid	-	50	-	60	-	70	ns
t _{DF1}	CE to Output in High Impedance	0	50	0	50	0	60	ns
t _{DF2}	OE to Output in High Impedance	0	50	0	50	0	60	ns
t _{OH}	Output Data Hold Time	0	-	0	-	0	-	ns
t _{BT}	BYTE to Output Valid	-	100	-	120	-	150	ns
t _{BT0}	BYTE to Output in High Impedance	-	60	-	60	-	70	ns

TC574200D-10 satisfies characteristics of TC574200D-120.

A.C. TEST CONDITIONS

- Output Load : 1 TTL Gate and CL = 100PF
- Input Pulse Rise and Fall Time : 10ns Max
- Input Pulse Levels : 0.45V and 2.4V
- Timing Measurement Reference Level : Input 0.8V and 2.2V, Output 0.8V and 2.0V

TC574200D-10, TC574200D-120 TC574200D-150

CAPACITANCE * (Ta = 25°C, f = 1MHz)

SYMBOL	PARAMETER	TEST CONDITION	MIN.	TYP.	MAX.	UNIT
C _{IN1}	Input Capacitance	V _{IN} = 0V	-	6	10	pF
C _{IN2}	Input Capacitance (BYTE / V _{PP})	V _{IN} = 0V	-	110	120	pF
C _{OUT}	Output Capacitance	V _{OUT} = 0V	-	10	12	pF

* This parameter is periodically sampled and is not 100% tested.

TIMING WAVEFORMS

WORD-WIDE READ MODE

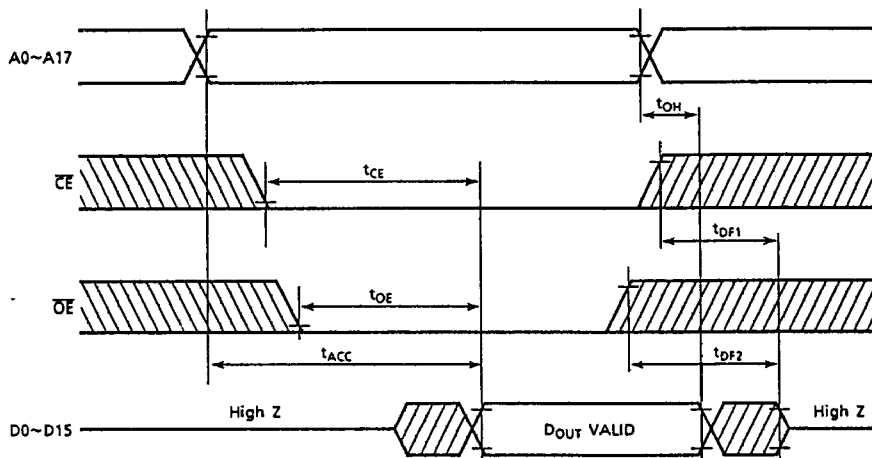

Note: $\overline{\text{BYTE}} / V_{PP} = V_{IH}$

BYTE - WIDE READ MODE

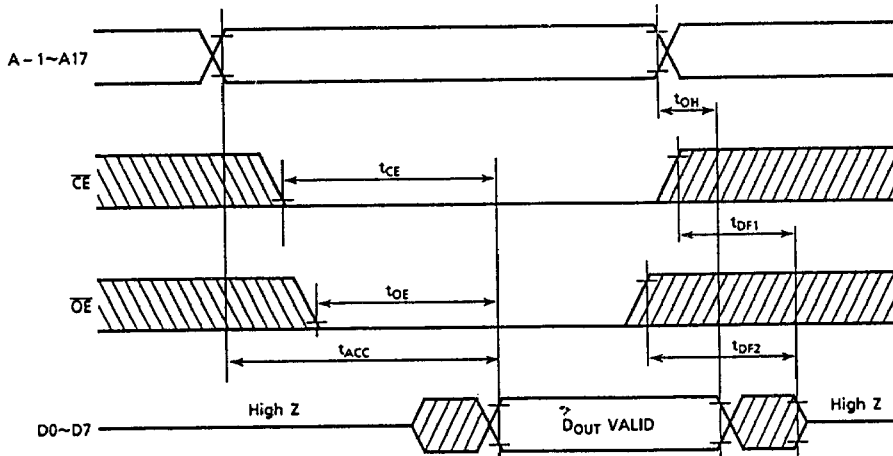

Note: $\overline{BYTE} / V_{PP} = V_{IL}$

BYTE TRANSITION

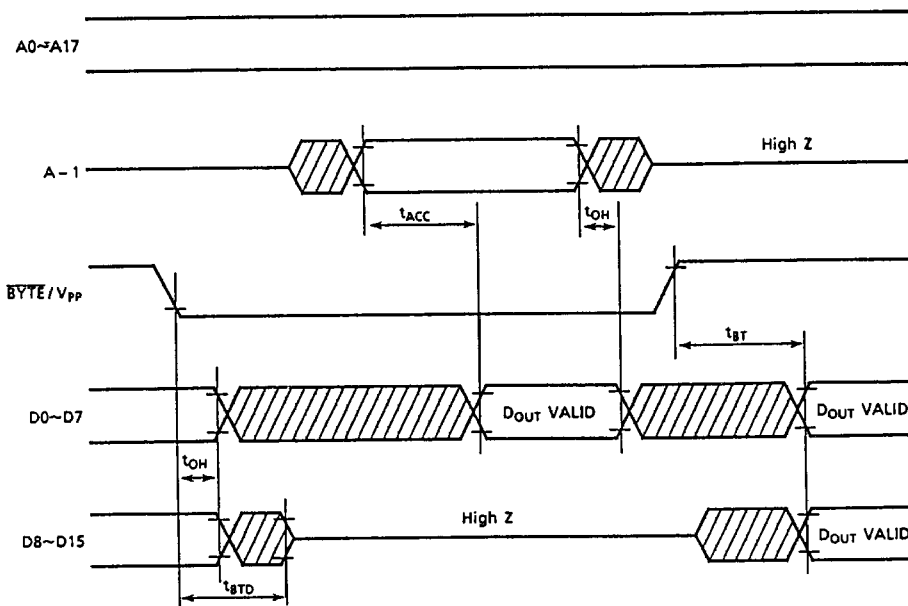

Note: $\overline{CE}, \overline{OE} = V_{IL}$

TC574200D-10, TC574200D-120 TC574200D-150

HIGH SPEED PROGRAM OPERATION

D.C. RECOMMENDED OPERATING CONDITIONS

SYMBOL	PARAMETER	MIN.	TYP.	MAX.	UNIT
V _{IH}	Input High Voltage	2.2	-	V _{CC} + 1.0	V
V _{IL}	Input Low Voltage	- 0.3	-	0.8	V
V _{CC}	V _{CC} Power Supply Voltage	6.00	6.25	6.50	V
V _{PP}	V _{PP} Power Supply Voltage	12.20	12.50	12.80	V

D.C. AND OPERATING CHARACTERISTICS (T_a = 25 ± 5°C, V_{CC} = 6.25 ± 0.25V, V_{PP} = 12.50 ± 0.30V)

SYMBOL	PARAMETER	TEST CONDITION	MIN.	TYP.	MAX.	UNIT
I _{LI}	Input Current	V _{IH} = 0V~V _{CC}	-	-	± 10	μA
V _{OH}	Output High Voltage	I _{OH} = -400μA	2.4	-	-	V
V _{OL}	Output Low Voltage	I _{OL} = 2.1mA	-	-	0.4	V
I _{CC}	V _{CC} Supply Current	-	-	-	40	mA
I _{PP2}	V _{PP} Supply Current	V _{PP} = 12.8V	-	-	50	mA

A.C. PROGRAMMING CHARACTERISTICS (T_a = 25 ± 5°C, V_{CC} = 6.25 ± 0.25V, V_{PP} = 12.50 ± 0.30V)

SYMBOL	PARAMETER	TEST CONDITION	MIN.	TYP.	MAX.	UNIT
t _{AS}	Address Setup Time	-	2	-	-	μs
t _{AH}	Address Hold Time	-	2	-	-	μs
t _{CES}	CE Setup Time	-	0	-	-	μs
t _{CEH}	CE Hold Time	-	0	-	-	μs
t _{OES}	OE Setup Time	-	2	-	-	μs
t _{DS}	Data Setup Time	-	2	-	-	μs
t _{DH}	Data Hold Time	-	2	-	-	μs
t _{VPS}	V _{PP} Setup Time	-	2	-	-	μs
t _{VCS}	V _{CC} Setup Time	-	2	-	-	μs
t _{PW}	Program Pulse Width	-	45	50	55	μs
t _{OPW}	Overprogram Pulse Width	Note 1	45	50	55	μs
t _{OE}	OE to Output Valid	CE = V _{IH}	-	-	100	ns
t _{DFP}	OE to Output in High Impedance	CE = V _{IH}	-	-	90	ns

A.C. TEST CONDITIONS

- Output Load : 1 TTL Gate and C_L = 100PF
- Input Pulse Rise and Fall Time : 10ns Max
- Input Pulse Levels : 0.45V and 2.4V
- Timing Measurement Reference Level : Input 0.8V and 2.2V, Output 0.8V and 2.0V

Note 1: t_{OPW} depends on the program pulse width which is required in the initial program.

TIMING WAVEFORMS

HIGH SPEED PROGRAM OPERATION

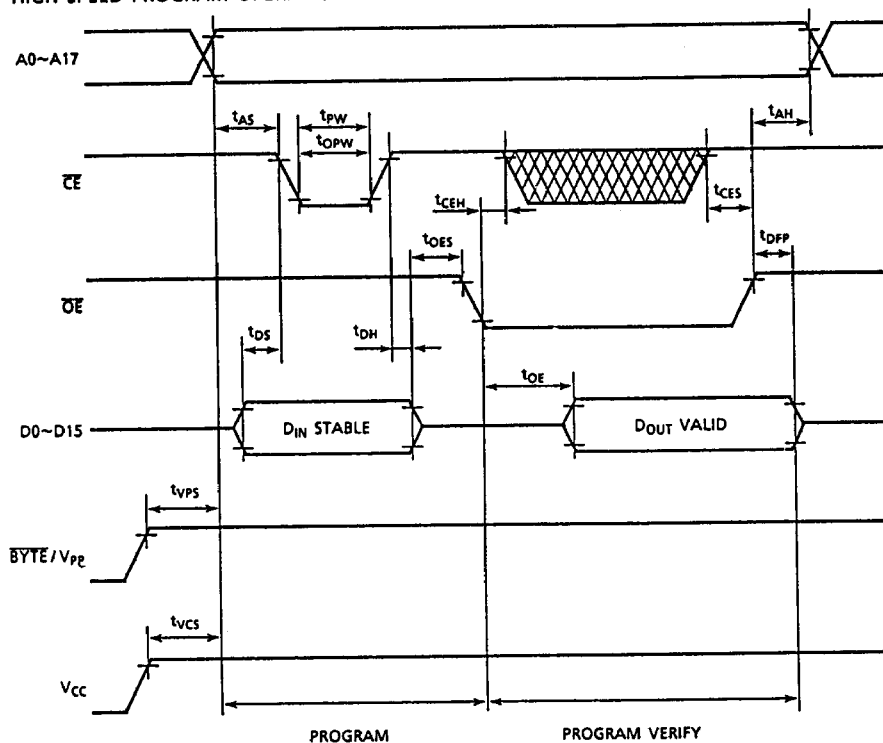

- Note: 1. V_{CC} must be applied simultaneously or before V_{pp} and cut off simultaneously or after V_{pp}.
2. Removing the device from socket and setting the device in socket with V_{pp}=12.50V may cause permanent damage to the device.
3. The V_{pp} supply voltage is permitted up to 14V for program operation. So the voltage over 14V should not be applied to the V_{pp} terminal. When the switching pulse voltage is applied to the V_{pp} terminal, the overshoot voltage of its pulse should not be exceeded 14V.

TC574200D-10, TC574200D-120 TC574200D-150

ERASURE CHARACTERISTICS

The TC574200D's erasure is achieved by applying shortwave ultraviolet light which has a wavelength of 2537Å (Angstroms) to the chip through the transparent window. Then integrated dose (ultraviolet light intensity [W/cm^2] \times exposure time [sec.]) for erasure should be a minimum of 15 [$W \cdot sec/cm^2$].

When the Toshiba sterilizing lamp GL-15 is used and the device is exposed at a distance of 1cm from the lamp surface, the erasure will be achieved within 60 minutes. And using commercial lamps whose ultraviolet light intensity is a 12000 [$\mu W/cm^2$] will reduce the exposure time to about 20 minutes. (In this case, the integrated dose is 12000 [$\mu W/cm^2$] \times (20 \times 60) [sec]=15 [$W \cdot sec/cm^2$].)

The TC574200D's erasure begins to occur when exposed to light with wavelength shorter than 4000Å. The sunlight and the fluorescent lamps will include 3000~4000Å wavelength components.

Therefore when used under such lighting for extended periods of time, the opaque seals - Toshiba EPROM Protect Seal AC907 - are available.

OPERATION INFORMATION

The TC574200D's eight operation mode are listed in the following table. Mode selection can be achieved by applying TTL level signal to all inputs.

MODE	PINS	\overline{CE}	\overline{OE}	BYTE / V_{PP}	V_{CC}	D0~D7	D8~D14	D15 / A-1	Power
Read (16 Bit)		L	L	H	5V	Data Out			Active
Read (Lower 8 Bit)		L	L	L		Data Out (Lower 8 Bit)	High Impedance	L	
Read (Upper 8 Bit)		L	L	L		Data Out (Upper 8 Bit)	High Impedance	H	
Output Deselect		L	H	H		High Impedance			
				L		High Impedance			
Standby		H	*	H		High Impedance			
				L	High Impedance				
Program		L	H		6.25V	Data In			Active
Program Inhibit		H	H	12.5V		High Impedance			
Program Verify		*	L			Data Out			

Note: H = V_{IH} , L = V_{IL} , * = V_{IH} or V_{IL}

READ MODE

The TC574200D has the $\overline{\text{BYTE}}/\text{V}_{\text{PP}}$ terminal that selects word-wide output and byte-wide output. When $\overline{\text{BYTE}}/\text{V}_{\text{PP}}$ is set to V_{IH} , the word-wide output is selected, and D15/A-1 pin is used for D15 data output.

When $\overline{\text{BYTE}}/\text{V}_{\text{PP}}$ is set to V_{IL} , the byte-wide output is selected, and D15/A-1 pin is used for A-1 address input. When A-1 is set to V_{IL} in this condition, the data output is selected lower 8 bits of the 16 bit data which has been programmed. When A-1 is set to V_{IH} , the data output is selected upper 8 bits.

The TC574200D has two control function. The chip enable ($\overline{\text{CE}}$) controls the operation power and should be used for device selection. The output enable ($\overline{\text{OE}}$) controls the output buffers, independent of device selection. Assuming that $\overline{\text{CE}} = \overline{\text{OE}} = \text{V}_{\text{IL}}$, the output data is valid at the outputs after address access time from stabilizing of all addresses. The $\overline{\text{CE}}$ to output valid (t_{CE}) is equal to the address access time (t_{ACC}). Assuming that $\overline{\text{CE}} = \text{V}_{\text{IL}}$ and all addresses are valid, the output data is valid at the outputs after t_{OE} from the falling edge of $\overline{\text{OE}}$.

OUTPUT Deselect MODE

Assuming that $\overline{\text{CE}} = \text{V}_{\text{IH}}$ or $\overline{\text{OE}} = \text{V}_{\text{IH}}$, the outputs will be in a high impedance state. So two or more TC574200D's can be connected together on a common bus line. When $\overline{\text{CE}}$ is decoded for device selection, all deselected devices are in low power standby mode.

STANDBY MODE

The TC574200D has a low power standby mode controlled by the $\overline{\text{CE}}$ signal. By applying a high level to the $\overline{\text{CE}}$ input, the TC574200D is placed in the standby mode which reduces the operating current to 100 μA by applying MOS-high level (V_{CC}) and then the outputs are in a high impedance state, independent of the $\overline{\text{OE}}$ input.

TC574200D-10, TC574200D-120 TC574200D-150

PROGRAM MODE

Initially, when received by customers, all bits of the TC574200D are in the "1" state which is erased state. Therefore the program operation is to introduce "0's" data into the desired bit location by electrically programming. The TC574200D is in the programming mode when the V_{pp} input is at 12.50V and \overline{CE} is at TTL-Low under $\overline{OE}=V_{IH}$. Data to be programmed must be applied 16 bits in parallel to the data pins.

The TC574200D can be programmed any location at anytime either individually, sequentially, or at random.

PROGRAM VERIFY MODE

The verify mode is to check that desired data is correctly programmed on the programmed bits.

The verify is accomplished with \overline{OE} at V_{IL} . The programmed data should be compared with the original word-wide (16 bit) data.

PROGRAM INHIBIT MODE

Under the condition that the program voltage (12.50V) is applied to V_{pp} terminal, a high level \overline{CE} input inhibits the TC574200D from being programmed. Programming of two or more EPROMs in parallel with different data is easily accomplished. That is, all inputs except for \overline{CE} and \overline{OE} may be commonly connected, and a TTL low level program pulse is applied to the \overline{CE} of the desired device only and TTL high level signal is applied to the other devices.

HIGH SPEED PROGRAM MODE

The device is set up the high speed programming mode when the programming voltage (12.50V) is applied to the V_{pp} terminal with $V_{CC}=6.25V$. The programming is achieved by applying a single TTL low level 50 μ s pulse to the \overline{CE} input after addresses and data are stable. Then the programmed data is verified by using Program Verify Mode. If the programmed data is not correct, another program pulse of 50 μ s is applied and then the programmed data is verified. This should be repeated until the program operates correctly(max. 25 times).

After correctly programming the selected address, the overprogram pulse of same length that needed for initial programming should be applied. When programming has been completed, the data in all addresses should be verified with $V_{CC}=V_{pp}=5V$.

HIGH SPEED PROGRAM MODE

FLOW CHART

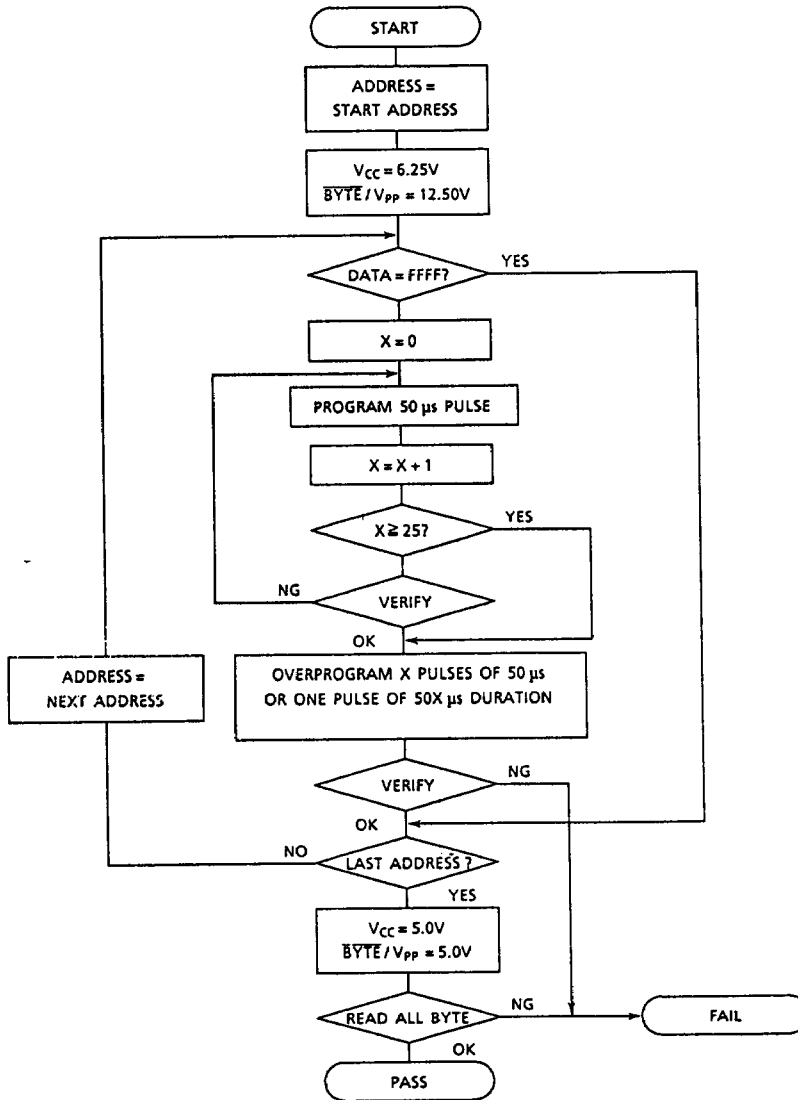

TC574200D-10, TC574200D-120 TC574200D-150

ELECTRIC SIGNATURE MODE

Electric signature mode allows to read out a code from TC574200D which identifies its manufacturer and device type. The programming equipment may read out manufacturer code and device code from TC574200D by using this mode before program operation and automatically set program voltage (V_{pp}) and algorithm.

Electric signature mode is set up when 12V is applied to address line A9 and the rest of address lines is set to V_{IL} in read operation. Data output in this condition is manufacturer code. Device code is identified when address A0 is set to V_{IH} . These two codes possess an odd parity with the parity bit of (D7).

The following table shows electric signature of TC574200D.

SIGNATURE \ PINS	A0	D15	D14	D13	D12	D11	D10	D9	D8	D7	D6	D5	D4	D3	D2	D1	D0	HEX DATA
Manufacturer Code	V_{IL}	*	*	*	*	*	*	*	*	1	0	0	1	1	0	0	0	**98
Device Code	V_{IH}	*	*	*	*	*	*	*	*	1	0	0	0	1	1	1	1	**8F

Note: A1 - A8, A10 - A17, \overline{CE} , $\overline{OE} = V_{IL}$
 $\overline{BYTE}/V_{PP} = V_{IH}$
 * Don't care

D.C. RECOMMENDED OPERATING CONDITIONS

SYMBOL	PARAMETER	MIN.	TYP.	MAX.	UNIT
V_{CC}	V_{CC} Power Supply Voltage	4.50	5.00	5.50	V
V_{ID}	A9 Auto Select Voltage	11.50	12.00	12.50	V

OUTLINE DRAWINGS

Unit in mm

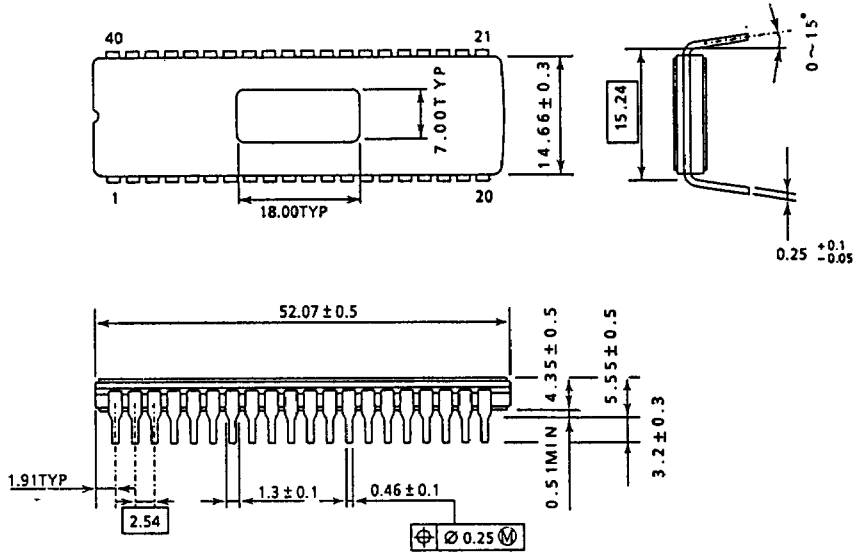

Weight : 12.20g (TYP.)