

NM27LC512

524,288-Bit (64k x 8) Low Current CMOS EPROM

General Description

The NM27LC512 is a 64k x 8 EPROM manufactured on a proven, manufacturable CMOS process, consuming extremely low current in both the active and standby modes. The NM27LC512 consumes a mere 30 mW, making it ideal for portable and hand held computers, data acquisition and medical equipment, and for systems using in-line power.

The NM27LC512 is one among a family of Power Miser products from National Semiconductor catering to the increasing low current demands of the market.

Offered in a JEDEC Standard Pinout, the NM27LC512 offers a viable alternative to the user as a replacement for existing high power devices, while also providing an upgrade path from lower densities.

Features

- Low CMOS power consumption
 - 5V operation
 - 8.0 mA (Max) active
 - 100 μ A (Max) standby
- 150 ns access time
- Latch-up immunity to 200 mA
- ESD protection exceeds 2000V
- JEDEC standard pinout
- Manufacturer's identification code

Block Diagram

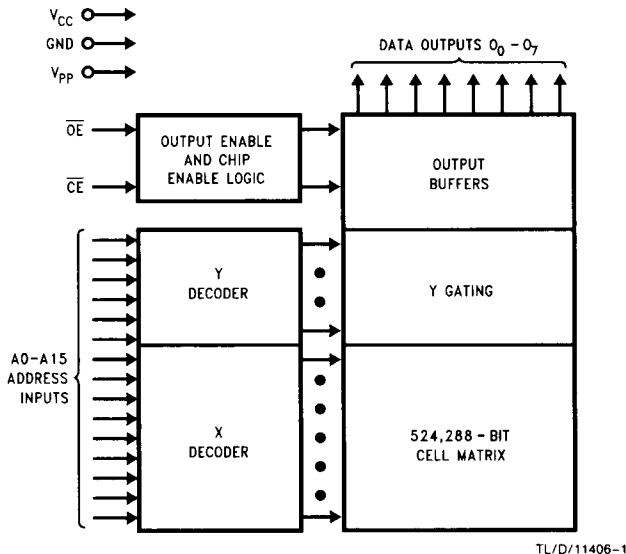

Pin Names

A0-A15	Addresses
CE	Chip Enable
OE/V _{PP}	Output Enable
O ₀ -O ₇	Outputs
PGM	Program
XX	Don't Care (During Read)

NM27LC512 524,288-Bit (64k x 8) Low Current CMOS EPROM

Connection Diagram

27LC010	27LC256
XX/V _{pp}	
A16	
A15	V _{pp}
A12	A12
A7	A7
A6	A6
A5	A5
A4	A4
A3	A3
A2	A2
A1	A1
A0	A0
O0	O0
O1	O1
O2	O2
GND	GND

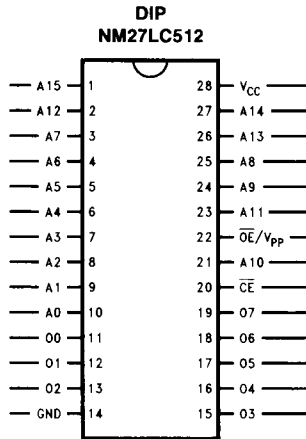

27LC256	27LC010
	V _{CC}
	XX/PGM
V _{CC}	XX
A14	A14
A13	A13
A8	A8
A9	A9
A11	A11
OE	OE
A10	A10
CE	CE
O7	O7
O6	O6
O5	O5
O4	O4
O3	O3

TL/D/11406-2

Note: Compatible EPROM plan configurations are shown in the blocks adjacent to the NM27LC256 plan.

Commercial Temperature Range
(0°C to +70°C)
V_{CC} = 5V ± 10%

Extended Temperature Range
(-40°C to +85°C)
V_{CC} = 5V ± 10%

Parameter/Order Number	Access Time (ns)
NM27LC256 Q, N 150	150
NM27LC256 Q, N 200	200
NM27LC256 Q, N 250	250

Parameter/Order Number	Access Time (ns)
NM27LC256 QE, NE 150	150
NM27LC256 QE, NE 200	200
NM27LC256 QE, NE 250	250

Ordering Information

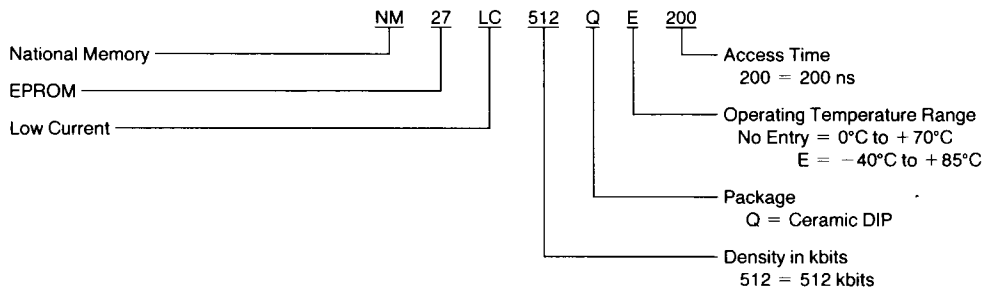

Absolute Maximum Ratings (Note 1)

If Military/Aerospace specified devices are required, please contact the National Semiconductor Sales Office/Distributors for availability and specifications.

Storage Temperature	-65°C to +150°C
All Input Voltages Except A9 with Respect to Ground	-0.6V to +7V
V _{PP} and A9 with Respect to Ground	-0.7V to +14V
V _{CC} Supply Voltage with Respect to Ground	-0.6V to +7V

ESD Protection > 2000V
 All Output Voltages with Respect to Ground V_{CC} + 1.0V to GND - 0.6V

Operating Range

Range	Temperature	V _{CC}
Commercial	0°C to +70°C	5V ± 10%
Industrial	-40°C to +85°C	5V ± 10%

Read Operation

DC Electrical Characteristics Over Operating Range with V_{PP} = V_{CC}

Symbol	Parameter	Conditions	Min	Typ	Max	Units
V _{IL}	Input Low Level		-0.2		0.8	V
V _{IH}	Input High Level		2.0		V _{CC} + 1	V
V _{OL}	Output Low Voltage	I _{OL} = 2.1 mA			0.4	V
V _{OH}	Output High Voltage	I _{OH} = -2.5 mA	3.5			V
I _{SB1}	V _{CC} Standby Current CMOS Inputs	$\overline{CE} = V_{CC} \pm 0.3V$	0.5	0.5	100	μA
I _{SB2}	V _{CC} Standby Current TTL Inputs	$\overline{CE} = V_{IH}$	0.1	0.1	1.0	mA
I _{CC1}	V _{CC} Active Current TTL Inputs	$\overline{CE} = \overline{OE} = V_{IL}$, f = 3 MHz Inputs = V _{IH} or V _{IL}		16.0	12.5	mA
I _{CC2}	V _{CC} Active Current CMOS Inputs	$\overline{CE} = GND$, f = 3 MHz Inputs = V _{CC} or GND, I/O = 0 mA (Refer to Figures 1, 2)	5.0	6.0	8.0	mA
I _{PP}	V _{PP} Supply Current	V _{PP} = V _{CC}			10	μA
I _{LI}	Input Load Current	V _{IN} = 5.5V or GND	-1		1	μA
I _{LO}	Output Leakage Current	V _{OUT} = 5.5V or GND	-10		10	μA

AC Electrical Characteristics Over Operating Range with V_{PP} = V_{CC}

Symbol	Parameter	150		200		250		Units
		Min	Max	Min	Max	Min	Max	
t _{ACC}	Address to Output Delay		150		200		250	ns
t _{CE}	\overline{CE} to Output Delay		150		200		250	
t _{OE}	\overline{OE} to Output Delay		60		75		100	
t _{DF} (Note 2)	Output Disable to Output Float		50		55		60	
t _{OH} (Note 2)	Output Hold from Addresses, \overline{CE} or \overline{OE} , whichever Occurred First		0		0		0	

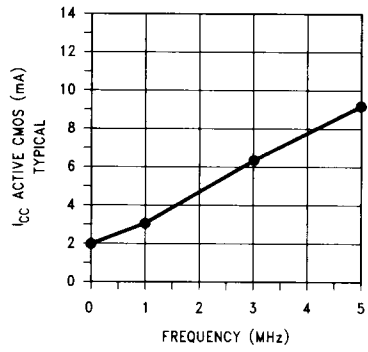

TL/D/11406-3

FIGURE 1. I_{CC} ACTIVE CMOS vs Frequency
V_{CC} = V_P = 5.0V, Temperature = 25°C

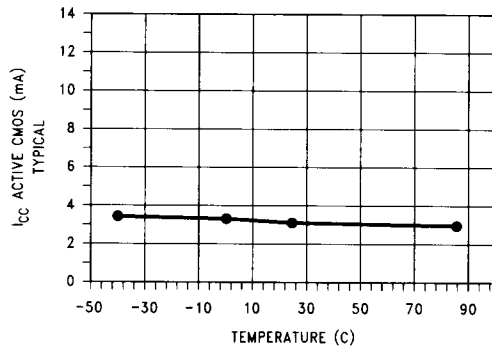

TL/D/11406-4

FIGURE 2. I_{CC} ACTIVE CMOS vs Temperature
V_{CC} = V_{PP} = 5.0V, Frequency = 1 MHz

Capacitance $T_A = +25^\circ\text{C}$, $f = 1\text{ MHz}$ (Note 2)

Symbol	Parameter	Conditions	Typ	Max	Units
C_{IN}	Input Capacitance	$V_{IN} = 0\text{V}$	6	12	pF
C_{OUT}	Output Capacitance	$V_{OUT} = 0\text{V}$	9	12	pF

AC Test Conditions

Output Load	1 TTL Gate and $C_L = 100\text{ pF}$ (Note 8)	Input Pulse Levels	0.45V to 2.4V
Input Rise and Fall Times	$\leq 5\text{ ns}$	Timing Measurement Reference Level	(Note 9)
		Inputs	0.8V to 2V
		Outputs	0.8V to 2V

AC Waveforms (Notes 6, 7, and 9)

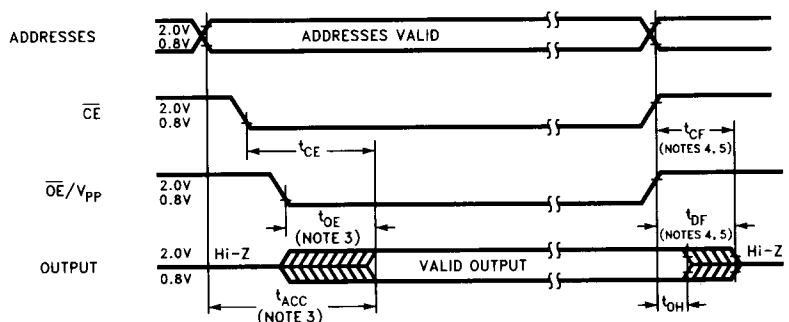

TL/D/11406-5

Note 1: Stresses above those listed under "Absolute Maximum Ratings" may cause permanent damage to the device. This is a stress rating only and functional operation of the device at these or any other conditions above those indicated in the operations sections of this specification is not implied. Exposure to absolute maximum rating conditions for extended periods may affect device reliability.

Note 2: This parameter is only sampled and is not 100% tested.

Note 3: \overline{OE} may be delayed up to $t_{ACC} - t_{CE}$ after the falling edge of \overline{CE} without impacting t_{ACC} .

Note 4: The T_{DF} and T_{CF} compare level is determined as follows:
High to TRI-STATE®, the measure V_{CH1} (DC) - 0.10V;
Low to TRI-STATE®, the measure V_{OL1} (DC) + 0.10V.

Note 5: TRI-STATE may be attained using \overline{OE} or \overline{CE} .

Note 6: The power switching characteristics of EPROMs require careful device decoupling. It is recommended that at least a 0.1 μF ceramic capacitor be used on every device between V_{CC} and GND.

Note 7: The outputs must be restricted to $V_{CC} + 1.0\text{V}$ to avoid latch-up and device damage.

Note 8: 1 TTL Gate: $I_{OL} = 1.6\text{ mA}$, $I_{OH} = -400\text{ }\mu\text{A}$.

C_L : 100 pF includes fixture capacitance.

Note 9: Inputs and outputs can undershoot to -2.0V for 20 ns Max.

Note 10: CMOS inputs $V_{IL} = \text{GND} \pm 0.3\text{V}$, $V_{IH} = V_{CC} \pm 0.3\text{V}$.

Programming Characteristics (Notes 1, 2, 3 and 4)

Symbol	Parameter	Conditions	Min	Typ	Max	Units
t_{AS}	Address Setup Time		1			μs
t_{OES}	\overline{OE} Setup Time		1			μs
t_{DS}	Data Setup Time		1			μs
t_{VCS}	V_{CC} Setup Time		1			μs
t_{AH}	Address Hold Time		0			μs
t_{DH}	Data Hold Time		1			μs
t_{cf}	Chip Enable to Output Float Delay	$\overline{OE} = V_{IL}$	0		60	ns
t_{PW}	Program Pulse Width		95	100	105	μs
t_{OEh}	\overline{OE} Hold Time		1			μs
t_{DV}	Data Valid from \overline{CE}	$\overline{OE} = V_{IL}$			250	ns
t_{PRT}	\overline{OE} Pulse Rise Time During Programming		50			ns
t_{VR}	V_{PP} Recovery Time		1			μs
I_{PP}	V_{PP} Supply Current During Programming Pulse	$\overline{CE} = V_{IL}$ $\overline{OE} = V_{PP}$			30	mA
I_{CC}	V_{CC} Supply Current				10	mA
T_R	Temperature Ambient		20	25	30	$^{\circ}\text{C}$
V_{CC}	Power Supply Voltage		6	6.25	6.5	V
V_{PP}	Programming Supply Voltage		12.5	12.75	13	V
t_{FR}	Input Rise, Fall Time		5			ns
V_{IL}	Input Low Voltage			0	0.45	V
V_{IH}	Input High Voltage		2.4	4		V
t_{IN}	Input Timing Reference Voltage		0.8	1.5	2	V
t_{OUT}	Output Timing Reference Voltage		0.8	1.5	2	V

Note 1: National's standard product warranty applies to devices programmed to specifications described herein.

Note 2: V_{CC} must be applied simultaneously or before V_{PP} and removed simultaneously or after V_{PP} . The EPROM must not be inserted into or removed from a board with voltage applied to V_{PP} or V_{CC} .

Note 3: The maximum absolute allowable voltage which may be applied to the V_{PP} pin during programming is 14V. Care must be taken when switching the V_{PP} supply to prevent any overshoot from exceeding this 14V maximum specification. At least 0.1 μF capacitor is required across V_{CC} to GND to suppress spurious voltage transients which may damage the device.

Note 4: Programming and program verify are tested with the fast Program Algorithm at typical power supply voltages and timings.

Programming Waveforms

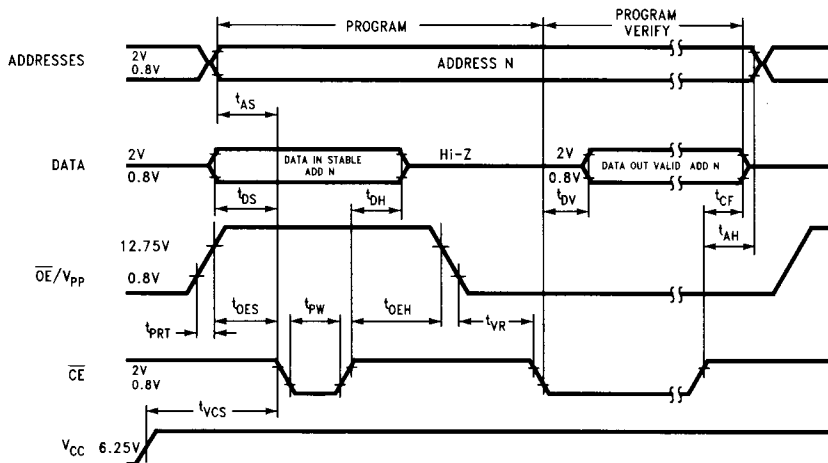

Interactive Programming Algorithm Flow Chart

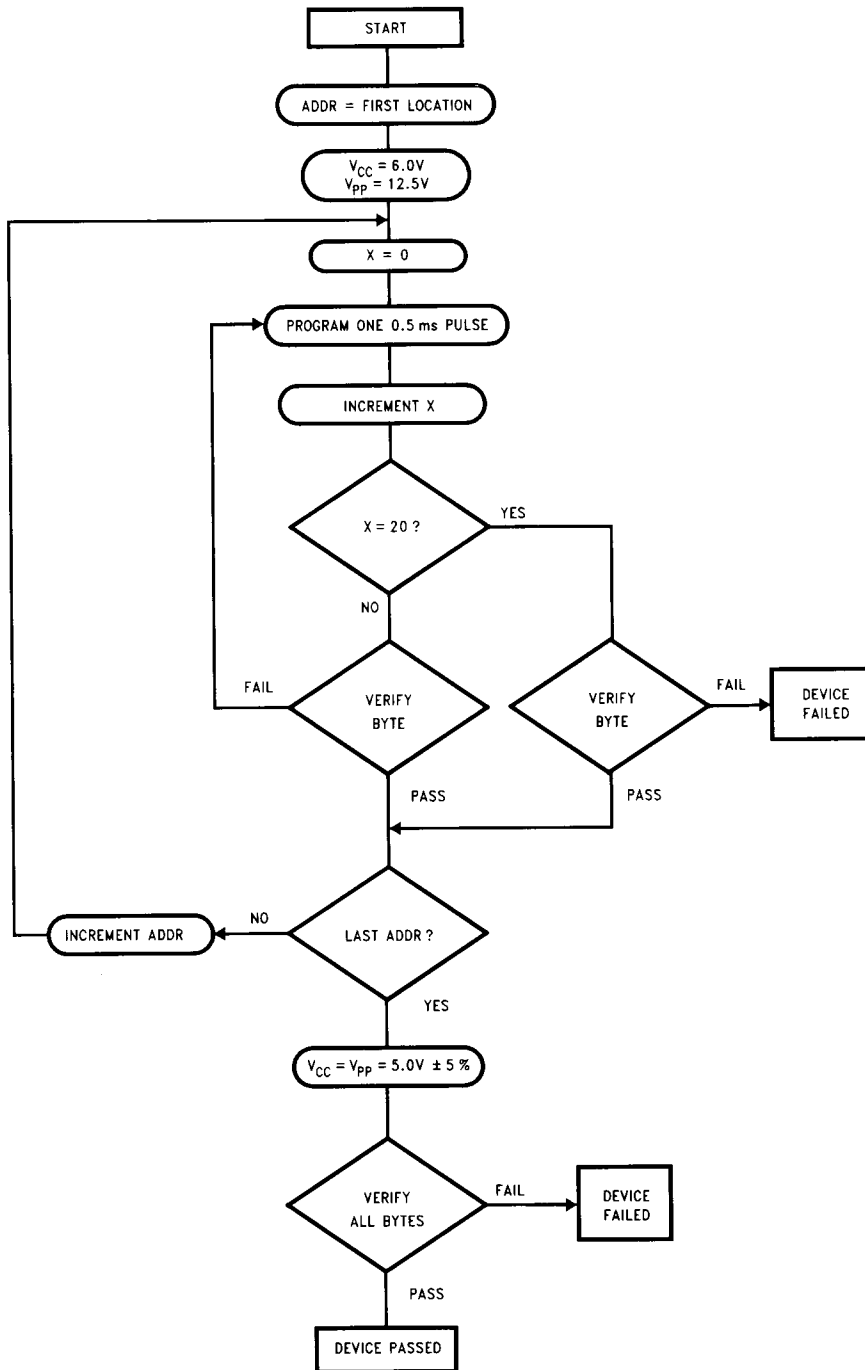

FIGURE 3

Fast Programming Algorithm Flow Chart

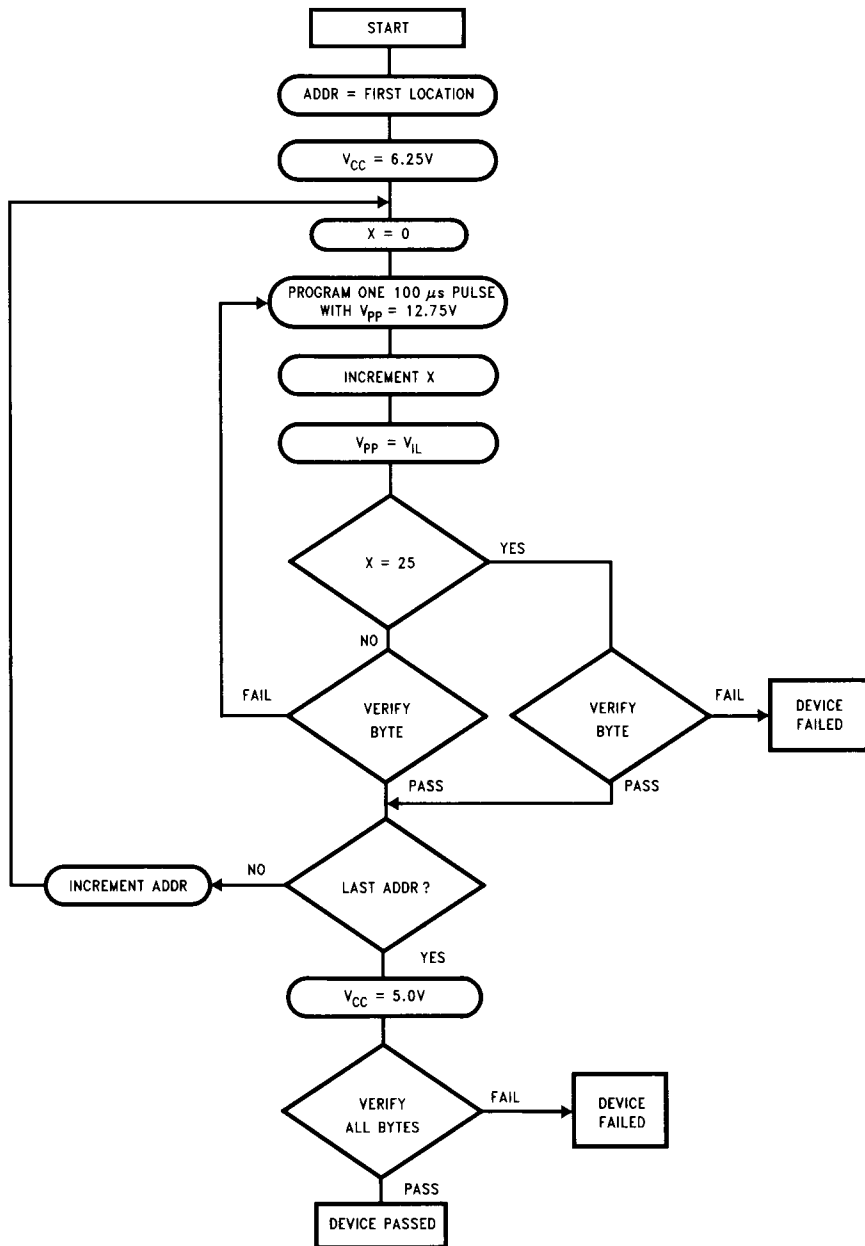

FIGURE 4

TL/D/11406-7

Functional Description

DEVICE OPERATION

The six modes of operation of the NM27LC512 are listed in Table I. A single 5V power supply is required in the read mode. All inputs are TTL levels except for \overline{OE}/V_{PP} during programming. In the program mode the \overline{OE}/V_{PP} input is pulsed from a TTL low level to 12.75V.

Read Mode

The NM27LC512 has two control functions, both of which must be logically active in order to obtain data at the outputs. Chip Enable (\overline{CE}) is the power control and should be used for device selection. Output Enable (\overline{OE}) is the output control and should be used to gate data to the output pins, independent of device selection. Assuming that addresses are stable, address access time (t_{ACC}) is equal to the delay from \overline{CE} to output (t_{CE}). Data is available at the outputs after the falling edge of \overline{OE} , assuming that \overline{CE} has been low and addresses have been stable for at least $t_{ACC}-t_{OE}$.

The sense amps are clocked for fast access time. V_{CC} should therefore be maintained at operating voltage during read and verify. If V_{CC} temporarily drops below the spec. voltage (but not to ground) an address transition must be performed after the drop to ensure proper output data.

Standby Mode

The NM27LC512 has a standby mode which reduces the active power dissipation by over 99%, from 44 mW to 0.55 mW. The NM27LC512 is placed in the standby mode by applying a CMOS high signal to the \overline{CE} input. When in standby mode, the outputs are in a high impedance state, independent of the \overline{OE} input.

Output OR-Typing

Because the NM27LC512 is usually used in larger memory arrays, National has provided a 2-line control function that accommodates this use of multiple memory connections. The 2-line control function allows for:

- a) the lowest possible memory power dissipation, and
- b) complete assurance that output bus contention will not occur.

To most efficiently use these two control lines, it is recommended that \overline{CE} (pin 20) be decoded and used as the primary device selecting function, while \overline{OE}/V_{PP} (pin 22) be made a common connection to all devices in the array and connected to the READ line from the system control bus.

This assures that all deselected memory devices are in their low power standby modes and that the output pins are active only when data is desired from a particular memory device.

Programming

CAUTION: Exceeding 14V on pin 22 (\overline{OE}/V_{PP}) will damage the NM27LC512.

Initially, and after each erasure, all bits of the NM27LC512 are in the "1" state. Data is introduced by selectively programming "0's" into the desired bit locations. Although only "0's" will be programmed, both "1's" and "0's" can be presented in the data word. The only way to change a "0" to a "1" is by ultraviolet light erasure.

The NM27LC512 is in the programming mode when the \overline{OE}/V_{PP} is at 12.75V. It is required that at least a 0.1 μ F capacitor be placed across V_{CC} and ground to suppress spurious voltage transients which may damage the device. The data to be programmed is applied 8 bits in parallel to the data output pins. The levels required for the address and data inputs are TTL.

When the address and data are stable, an active low, TTL program pulse is applied to the \overline{CE} input. A program pulse must be applied at each address location to be programmed.

The NM27LC512 is programmed with the Fast Programming Algorithm shown in Figure 4. Each Address is programmed with a series of 100 μ s pulses until it verifies good, up to a maximum of 25 pulses. Most memory cells will program with a single 100 μ s pulse.

The NM27LC512 must not be programmed with a DC signal applied to the \overline{CE} input.

Programming multiple NM27LC512 in parallel with the same data can be easily accomplished due to the simplicity of the programming requirements. Like inputs of the paralleled NM27LC512 may be connected together when they are programmed with the same data. A low level TTL pulse applied to the \overline{CE} input programs the paralleled NM27LC512.

Note: Some programmer manufacturers due to equipment limitation may offer interactive program Algorithm (Shown in Figure 3).

Mode Selection

The modes of operation of the NM27LC512 are listed in Table I. A single 5V power supply is required in the read mode. All inputs are TTL levels except for V_{PP} and A9 for device signature.

TABLE I. Modes Selection

Pins	\overline{CE}/PGM	\overline{OE}	V_{PP}	V_{CC}	Outputs
Read	V_{IL}	V_{IL}	V_{CC}	5.0V	D_{OUT}
Output Disable	X (Note 1)	V_{IH}	V_{CC}	5.0V	High Z
Standby	V_{IH}	X	V_{CC}	5.0V	High Z
Programming	V_{IL}	X	12.75V	6.25V	D_{IN}
Program Verify	X	V_{IL}	12.75V	12.75V	D_{OUT}
Program Inhibit	V_{IH}	V_{IH}	12.75V	6.25V	High Z

Note 1: X can be V_{IL} or V_{IH} .

Functional Description (Continued)

Program Inhibit

Programming multiple NM27LC512 in parallel with different data is also easily accomplished. Except for \overline{CE} , all like inputs (including \overline{OE}) of the parallel NM27LC512 may be common. A TTL low level program pulse applied to an NM27LC512's \overline{CE} input with \overline{OE}/V_{PP} at 12.75V will program that NM27LC512. A TTL high level \overline{CE} input inhibits the other NM27LC512 from being programmed.

Program Verify

A verify should be performed on the programmed bits to determine whether they were correctly programmed. The verify is accomplished with \overline{OE}/V_{PP} and \overline{CE} at V_{IL} . Data should be verified t_{DV} after the falling edge of \overline{CE} .

Manufacturer's Identification Code

The NM27LC512 has a manufacturer's identification code to aid in programming. The code, shown in Table II, is two bytes wide and is stored in a ROM configuration on the chip. It identifies the manufacturer and the device type. The code for the NM27LC512 is "8F 85", where "8F" designates that it is made by National Semiconductor, and "85" designates a 512k part.

The code is accessed by applying 12V $\pm 0.5V$ to address pin A9. Addresses A1–A8, A10–A15, \overline{CE} , and \overline{OE} are held at V_{IL} . Address A0 is held at V_{IL} for the manufacturer's code, and at V_{IH} for the device code. The code is read on the 8 data pins. Proper code access is only guaranteed at 25°C $\pm 5^\circ C$.

The primary purpose of the manufacturer's identification code is automatic programming control. When the device is inserted in an EPROM programmer socket, the programmer reads the code and then automatically calls up the specific programming algorithm for the part. This automatic programming control is only possible with programmers which have the capability of reading the code.

ERASURE CHARACTERISTICS

The erasure characteristics of the NM27LC512 are such that erasure begins to occur when exposed to light with wavelengths shorter than approximately 4000 Angstroms (\AA). It should be noted that sunlight and certain types of fluorescent lamps have wavelengths in the 3000 \AA –4000 \AA range.

After programming opaque labels should be placed over the NM27LC512 window to prevent unintentional erasure. Covering the window will also prevent temporary functional failure due to the generation of photo currents.

The recommended erasure procedure for the NM27LC512 is exposure to short wave ultraviolet light which has a wavelength of 2537 \AA . The integrated dose (i.e., UV intensity \times exposure time) for erasure should be a minimum of 15W-sec/cm².

The NM27LC512 should be placed within 1 inch of the lamp tubes during erasure. Some lamps have a filter on their tubes which should be removed before erasure. Table III shows the minimum NM27LC512 erasure time for various light intensities.

An erasure system should be calibrated periodically. The distance from lamp to unit should be maintained at one inch. The erasure time increases as the square of the distance. (If distance is doubled the erasure time increases by a factor of 4.) Lamps lose intensity as they age. When a lamp is changed, the system should be checked to make certain full erasure is occurring. Incomplete erasure will cause symptoms that can be misleading. Programmers, components, and even system designs have been erroneously suspected when incomplete erasure was the problem.

SYSTEM CONSIDERATION

The power switching characteristics of EPROMs require careful decoupling of the devices. The supply current, I_{CC} , has three segments that are of interest to the system designer—the standby current level, the active current level, and the transient current peaks that are produced by voltage transitions on input pins. The magnitude of these transient current peaks is dependent on the output capacitance loading of the device. The associated V_{CC} transient voltage peaks can be suppressed by properly selected decoupling capacitors. It is recommended that at least a 0.1 μF ceramic capacitor be used on every device between V_{CC} and GND. This should be a high frequency capacitor of low inherent inductance. In addition, at least a 4.7 μF bulk electrolytic capacitor should be used between V_{CC} and GND for each eight devices. The bulk capacitor should be located near where the power supply is connected to the array. The purpose of the bulk capacitor is to overcome the voltage drop caused by the inductive effects of the PC board traces.

TABLE II. Manufacturer's Identification Code

Pins	A0 (10)	A9 (24)	O7 (19)	O6 (18)	O5 (17)	O4 (16)	O3 (15)	O2 (13)	O1 (12)	O0 (11)	Hex Data
Manufacturer Code	V_{IL}	12V	1	0	0	0	1	1	1	1	8F
Device Code	V_{IH}	12V	0	0	0	0	0	1	0	0	04

TABLE III. Minimum NM27LC512 Erasure Time

Light Intensity (Micro-Watts/cm ²)	Erasure Time (Minutes)
15,000	20
10,000	25
5,000	50

Physical Dimensions inches (millimeters)

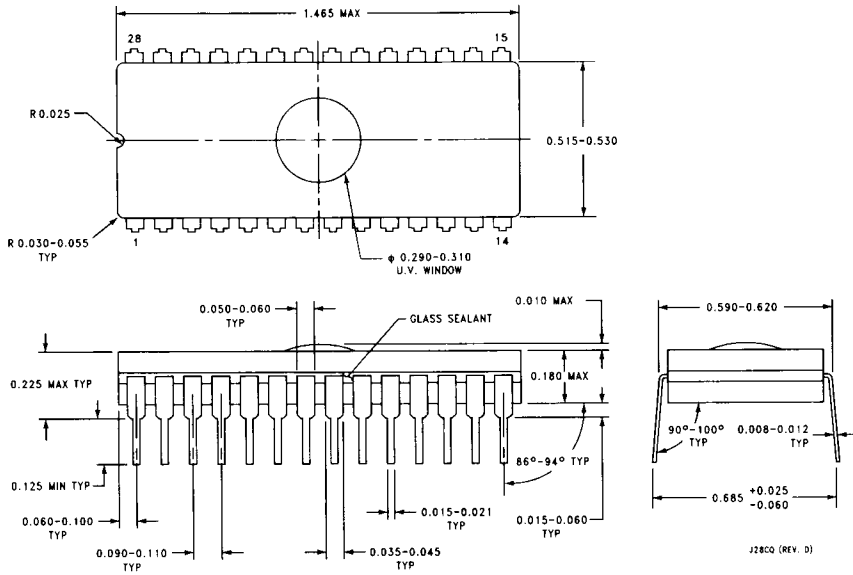

J28CQ (REV. D)

UV Window Cavity Dual-In-Line CERDIP Package (Q)
Order Number NM27LC512QXXX
NS Package Number J28CQ (D)

Physical Dimensions inches (millimeters) (Continued)

Lit # 112260

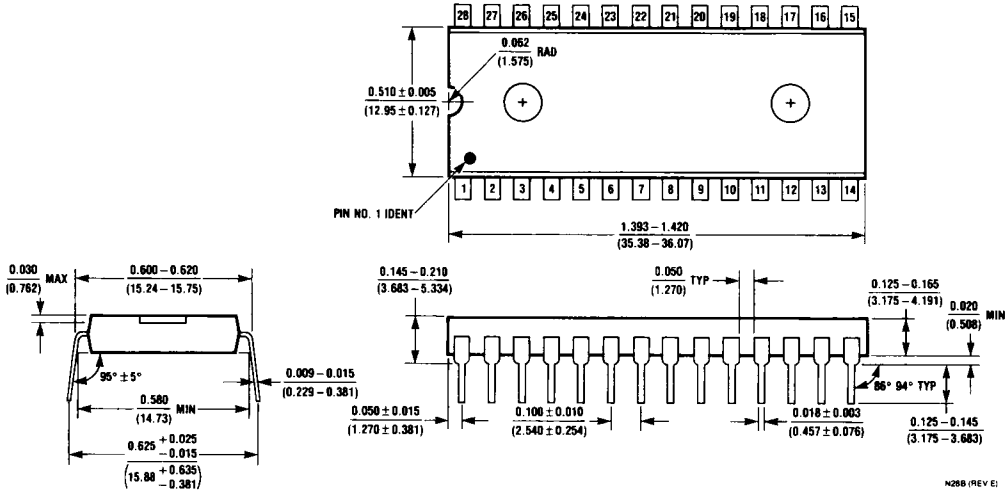

28-Lead Plastic One-Time-Programmable Dual-In-Line Package
Order Number NM27LC512NXXX
NS Package Number N28B

LIFE SUPPORT POLICY

NATIONAL'S PRODUCTS ARE NOT AUTHORIZED FOR USE AS CRITICAL COMPONENTS IN LIFE SUPPORT DEVICES OR SYSTEMS WITHOUT THE EXPRESS WRITTEN APPROVAL OF THE PRESIDENT OF NATIONAL SEMICONDUCTOR CORPORATION. As used herein:

1. Life support devices or systems are devices or systems which, (a) are intended for surgical implant into the body, or (b) support or sustain life, and whose failure to perform, when properly used in accordance with instructions for use provided in the labeling, can be reasonably expected to result in a significant injury to the user.
2. A critical component is any component of a life support device or system whose failure to perform can be reasonably expected to cause the failure of the life support device or system, or to affect its safety or effectiveness.

030429 ✓ R



National Semiconductor Corporation
 2900 Semiconductor Drive
 P.O. Box 58090
 Santa Clara, CA 95052-8090
 Tel: 1(800) 272-9959
 TWX: (910) 339-9240

National Semiconductor GmbH
 Industriestrasse 10
 D-9000 Furstenfeldbruck
 West Germany
 Tel: (0-81-41) 103-0
 Telex: 527-649
 Fax: (08141) 103554

National Semiconductor Japan Ltd.
 Sansedo Bldg. 5F
 4-15 Nishi-Shinjuku
 Shinjuku-Ku,
 Tokyo 160, Japan
 Tel: 33-299-7001
 FAX: 33-299-7000

National Semiconductor Hong Kong Ltd.
 Suite 513, 5th Floor
 Chinachem Golden Plaza,
 77 Mody Road, Tsimshatsui East,
 Kowloon, Hong Kong
 Tel: 3-7231290
 Telex: 52996 NSSEA HX
 Fax: 3-3112536

National Semicondutores Do Brasil Ltda.
 Av. B'ng. Faria Lima, 1383
 6.0 Andor-Conj. 52
 01451 Sao Paulo, SP, Brasil
 Tel: (55/11) 212-5066
 Fax: (55/11) 211-1181 NSBR BR

National Semiconductor (Australia) Pty, Ltd.
 1st Floor, 441 St. Kilda Rd
 Melbourne, 3004
 Victoria, Australia
 Tel: (03) 267-5000
 Fax: 61-3-2677458